



WINSTAR Display Co.,Ltd.
華凌光電股份有限公司



Winstar Display Co., LTD

華凌光電股份有限公司



WEB: <https://www.winstar.com.tw> E-mail: sales@winstar.com.tw

SPECIFICATION

CUSTOMER : _____

MODULE NO.: WF57VTIACDNN0#

<p>APPROVED BY: (FOR CUSTOMER USE ONLY)</p>	<p>PCB VERSION: _____ DATA: _____</p>
--	---

SALES BY	APPROVED BY	CHECKED BY	PREPARED BY
			葉虹蘭
ISSUED DATE: 2022/12/13			

TFT Display Inspection Specification: <https://www.winstar.com.tw/technology/download.html>

Precaution in use of TFT module: <https://www.winstar.com.tw/technology/download/declaration.html>



RECORDS OF REVISION

DOC. FIRST ISSUE

VERSION	DATE	REVISED PAGE NO.	SUMMARY
0	2022/12/13		First issue

WINSTAR DISPLAY Co., Ltd.

Contents

1.Module Classification Information

2.Summary

3.General Specifications

4.Absolute Maximum Ratings

5.Electrical Characteristics

6.AC Characteristics

7.Waveform

8.Optical Characteristics

9.Interface

10.Block Diagram

11.Reliability

12.Contour Drawing

13.Other

WINSTAR DISPLAY Co., Ltd.

1.Module Classification Information

W F 57 V T I A C D N N 0 #
 ① ② ③ ④ ⑤ ⑥ ⑦ ⑧ ⑨ ⑩ ⑪ ⑫ ⑬

①	Brand : WINSTAR DISPLAY CORPORATION											
②	Display Type : F→TFT Type, J→Custom TFT											
③	Display Size : 5.7" TFT											
④	Model serials no.											
⑤	Backlight Type :	F→CCFL, White S→LED, High Light White				T→LED, White Z→Nichia LED, White						
⑥	LCD Polarize Type/ Temperature range/ Gray Scale Inversion Direction	A→Transmissive, N.T, IPS TFT C→Transmissive, N. T, 6:00 ; F→Transmissive, N.T,12:00 ; I→Transmissive, W. T, 6:00 K→Transflective, W.T,12:00 L→Transmissive, W.T,12:00 N→Transmissive, Super W.T, 6:00				Q→Transmissive, Super W.T, 12:00 R→Transmissive, Super W.T, O-TFT V→Transmissive, Super W.T, VA TFT W→Transmissive, Super W.T, IPS TFT X→Transmissive, W.T, VA TFT Y→Transmissive, W.T, IPS TFT Z→Transmissive, W.T, O-TFT						
⑦	A : TFT LCD B : TFT+SCREW HOLES+CONTROL BOARD C : TFT+ SCREW HOLES +A/D BOARD D : TFT+ SCREW HOLES +A/D BOARD+CONTROL BOARD E : TFT+ SCREW HOLES +POWER BOARD				F : TFT+CONTROL BOARD G : TFT+ SCREW HOLES H : TFT+D/V BOARD I : TFT+ SCREW HOLES +D/V BOARD J : TFT+POWER BD							
⑧	Resolution:											
	A	128160	B	320234	C	320240	D	480234	E	480272	F	640480
	G	800480	H	1024600	I	320480	J	240320	K	800600	L	240400
	M	1024768	N	128128	P	1280800	Q	480800	R	640320	S	480128
	T	800320	U	8001280	V	176220	W	1280398	X	1024250	Y	1920720
	Z	800200	2	1024324	3	7201280	4	19201200	5	1366768	6	1280320
⑨	D: Digital L : LVDS M:MIPI											
⑩	Interface:											
	N	Without control board			A	8Bit	B	16Bit		H	HDMI	
	I	I2C Interface			R	RS232	S	SPI Interface		U	USB	
⑪	TS:											
	N	Without TS			T	Resistive touch panel		C	Capacitive touch panel (G-F-F)			
	G	Capacitive touch panel (G-G)				C1	Capacitive touch panel (G-F-F)+OCA					
	C2	Capacitive touch panel (G-F-F)+OCR				G1	Capacitive touch panel (G-G)+OCA					
	G2	Capacitive touch panel (G-G)+OCR				B	CTP+GG+USB					
⑫	Version: X:Raspberry pi											
⑬	Special Code	#:Fit in with ROHS directive regulations										

--	--	--

WINSTAR DISPLAY Co., Ltd.

2.Summary

TFT 5.7” is a TN transmissive type color active matrix TFT liquid crystal display that use amorphous silicon TFT as switching devices. This module is a composed of a TFT_LCD module, It is usually designed for industrial application and this module follows RoHs.

WINSTAR DISPLAY Co., Ltd.

3. General Specifications

Item	Dimension	Unit
Size	5.7	inch
Dot Matrix	320 x RGBx240(TFT)	dots
Module dimension	160(W) x 109(H) x 8.25 (D)	mm
Active area	115.2 x 86.40	mm
Dot pitch	0.12 x 0.36	mm
LCD type	TFT, Normally White, Transmissive	
View Direction	12 o'clock	
Gray Scale Inversion Direction	6 o'clock	
TFT Interface	24-bit RGB	
TFT Drive IC	HX8218+HX8615 or equivalent	
Aspect Ratio	4:3	
Backlight Type	LED, Normally White	
With /Without TP	Without TP	
Surface	Glare	

*Color tone slight changed by temperature and driving voltage.

4. Absolute Maximum Ratings

Item	Symbol	Min	Typ	Max	Unit
Operating Temperature	TOP	-20	—	+70	°C
Storage Temperature	TST	-30	—	+80	°C

Note: Device is subject to be damaged permanently if stresses beyond those absolute maximum ratings listed above

1. Temp. $\leq 60^{\circ}\text{C}$, 90% RH MAX. Temp. $> 60^{\circ}\text{C}$, Absolute humidity shall be less than 90% RH at 60°C

WINSTAR DISPLAY Co., Ltd

5. Electrical Characteristics

5.1. Operating conditions

Item	Symbol	Min	Typ	Max	Unit	Remark
Supply Voltage For LCM	VCC	3.2	3.3	3.4	V	—
Supply Current For LCM	ICC	—	30	45	mA	Note1
Input High Volt.	VIH	0.7 VCC	—	VCC	V	—
Input Low Volt.	VIL	0	—	0.3 VCC	V	—
LCD Driving Supply Voltage	VGH	15	16	17	V	—
	VGL	-6	-5	-4	V	—
	VCOMH	—	4.5	—	V	—
	VCOML	—	-0.5	—	V	—
	AVDD	4.5	5.0	5.5	V	—

Note 1 : This value is test for VCC =3.3V , Ta=25 °C only

5.2. LED driving conditions

Parameter	Symbol	Min.	Typ.	Max.	Unit	Remark
LED current	-	-	140	-	mA	-
Power Consumption	-	1260	-	1470	mW	-
LED voltage	VBL+	9.0	-	10.5	V	Note 1
LED Life Time	-	-	50,000	-	Hr	Note 2,3,4

Note 1 : There are 1 Groups LED

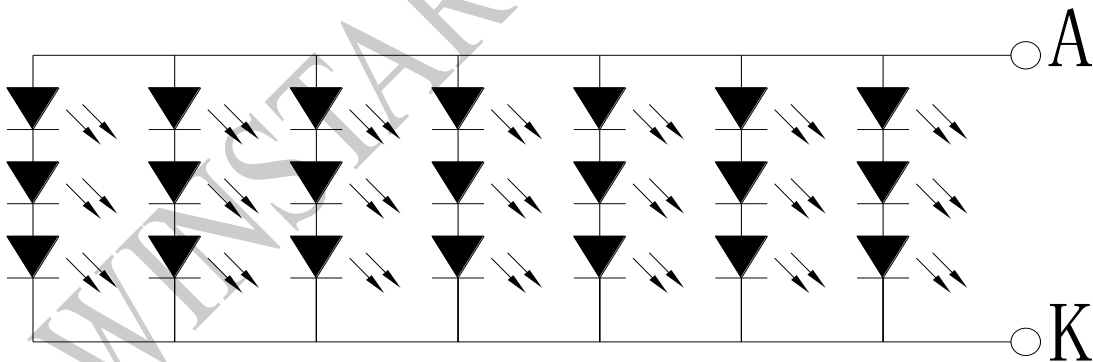

Note 2 : Ta = 25 °C

Note 3 : Brightness to be decreased to 50% of the initial value

Note 4 : The single LED lamp case.

6.AC CHARACTERISTICS

6.1. CCIR601/656 Interface

Input signal characteristics

Parameter	Symbol	Min.	Typ.	Max.	Unit
CLK period	Tosc	-	37	-	ns
Data setup time	Tsu	12	-	-	ns
Data hold time	THo	12	-	-	ns

Hardware reset timing

Parameter	Symbol	Min.	Typ.	Max.	Unit
Reset low pulse width	TRSB	10	-	-	μ s

Output signal characteristics

Parameter	Symbol	Min.	Typ.	Max.	Unit
Rising time	Tr	-	-	10	ns
Falling time	Tf	-	-	10	ns
Internal STH setup time	Tsus	12	-	-	ns
Internal STH hold time	THDS	12	-	-	ns
Internal data setup time	TSUD	60	-	-	ns
Internal I data hold time	THDD	40	-	-	ns
OEH pulse width	TOEH	-	1248	-	ns
OEV pulse width	TOEV	-	4992	-	ns
CKV pulse width	TCKV	-	3744	-	ns
Hsync-DEH time	T1	-	4368	-	ns
Hsync-CKV time	T2	-	2496	-	ns
Hsync-OEV time	T3	-	624	-	ns
Vsync-setup time	TSUV	-	1872	-	ns
Vsync-pulse time	TSTV	-	1	-	TH
Vsync-STV time	NTSC	Tvs1	-	19	TH
	PAL	Tvs1	-	27	TH
OEH-STV time	THE	-	2	-	TH
Output settling time	TOES	-	12	20	μ s

6.2. 24-bits parallel RGB Interface

AC Timing Characteristics

Signal	Item	Symbol	Min.	Typ.	Max.	Unit	
Dclk	Frequency	Dclk	-	6.4	-	MHZ	
	High time	Tch	-	78	-	ns	
	Low time	Tcl	-	78	-	ns	
Hsync	Period	TH	-	408	-	DCLK	
	Pulse Width	Thp	-	30	-	DCLK	
	Back-Porch	Thb	-	38	-	DCLK	
	Display Period	Thd	-	320	-	DCLK	
	Front-Porch	Thf	-	20	-	DCLK	
Vsync	Period	NTSC	TV	-	262.5	-	DCLK
		PAL		-	312.5	-	
	Pulse Width		Tvp	1	3	5	TH
	Back-Porch	NTSC	Tvb	-	15	-	TH
		PAL		-	23	-	
	Display Period		Tvd	-	240	-	TH
	Front-Porch	NTSC	Tvf	-	4.5	-	TH
PAL		-		46.5	-		

AC Timing Diagrams

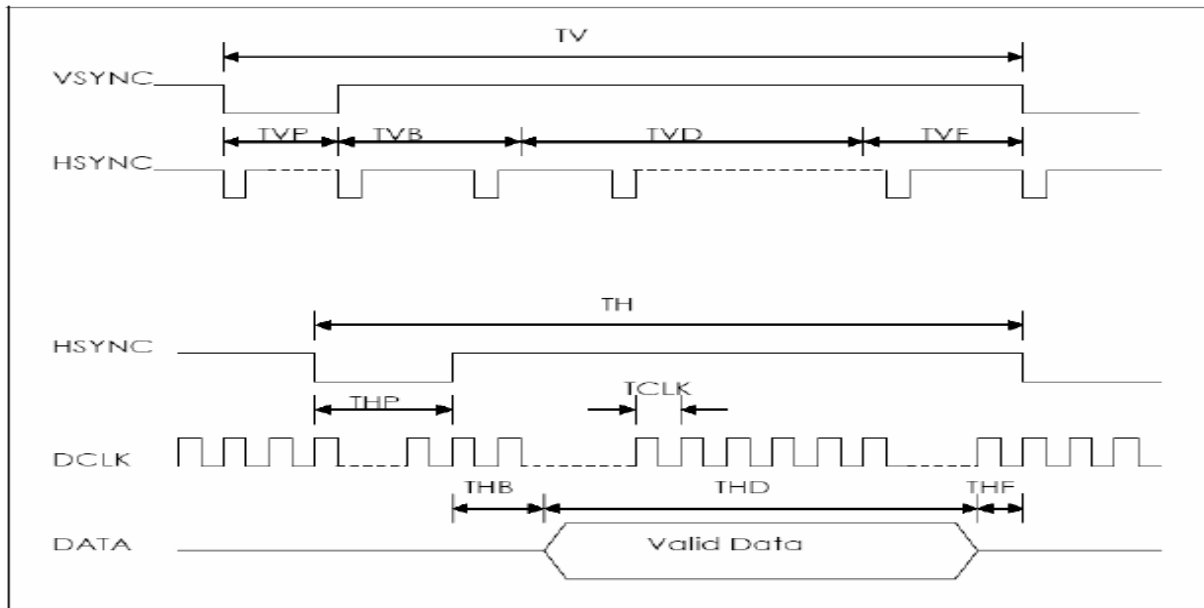

7.4. Hsync and vertical shift clock timing waveform

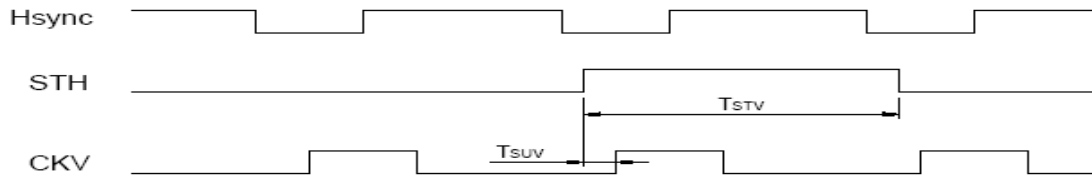

7.5. Hsync and vertical shift clock timing waveform

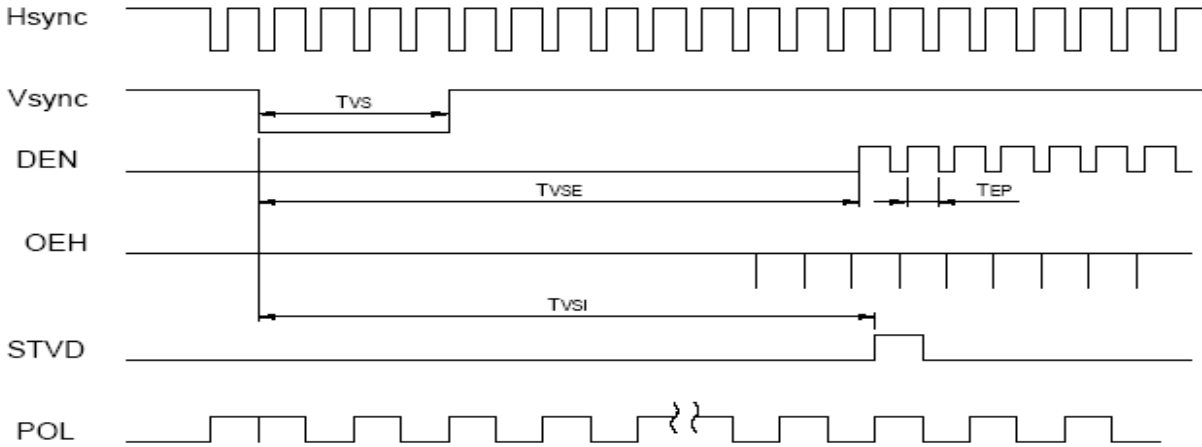

7.6. CCIR601 timing waveform (VS_POL="H" , HS_POL="L" in Register R2)

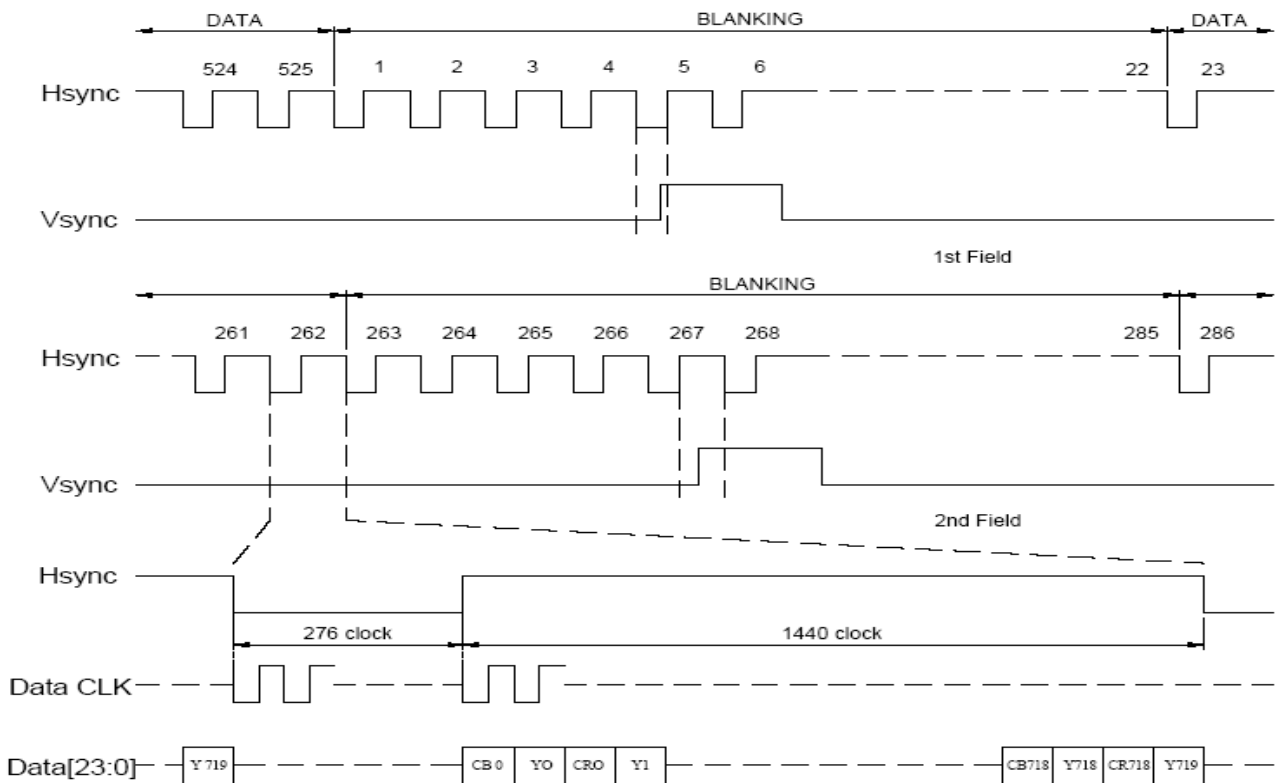

ITU-BT.601 NTSC Input Timing

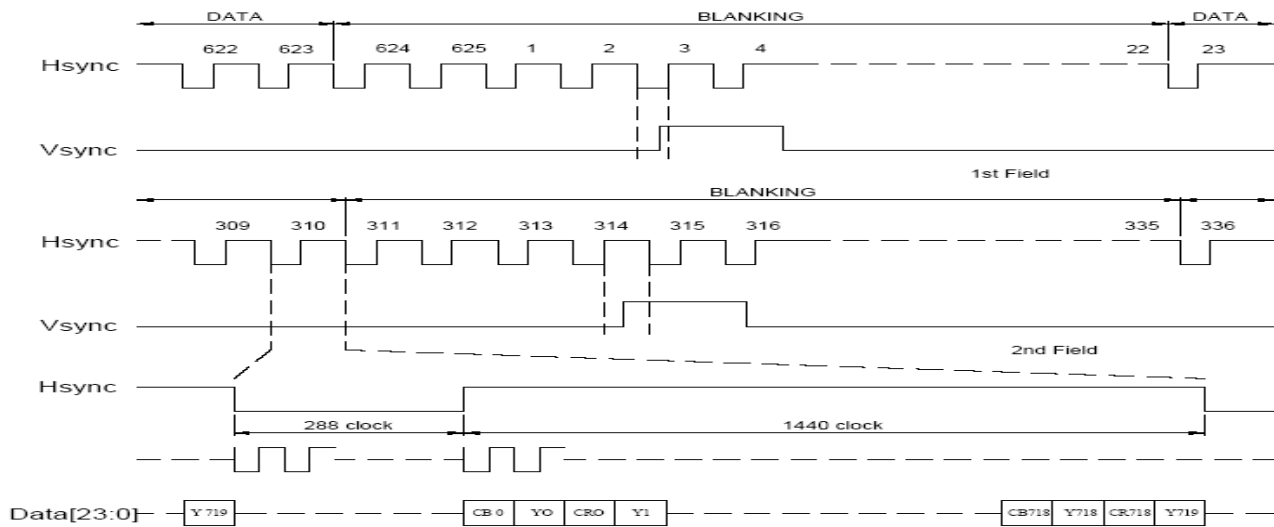

ITU-BT.601 PAL Input Timing

7.7. Source Driver Timing Chart Clock and Start Pulse timing waveform

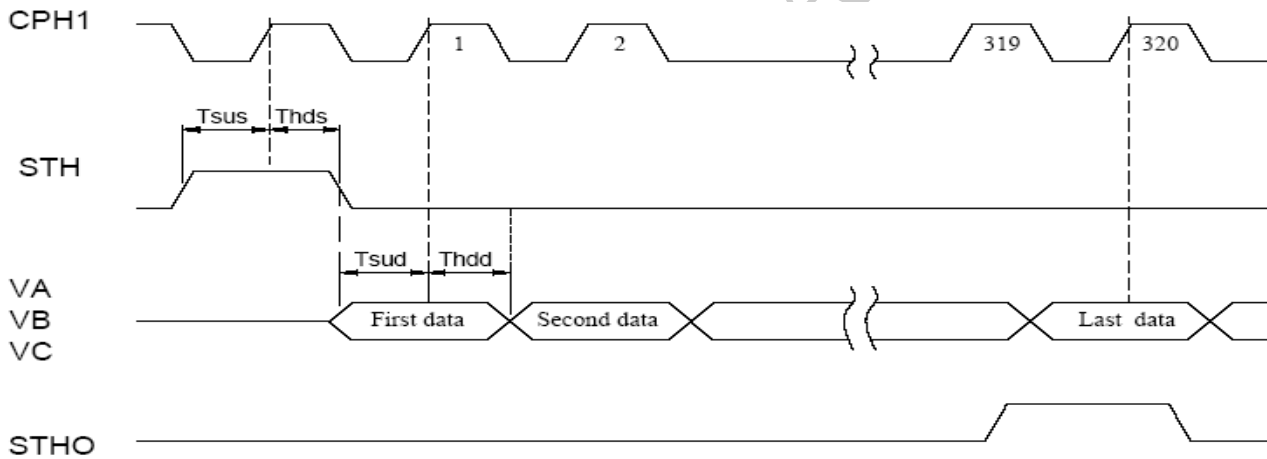

7.8. OEH and Data Output timing waveform

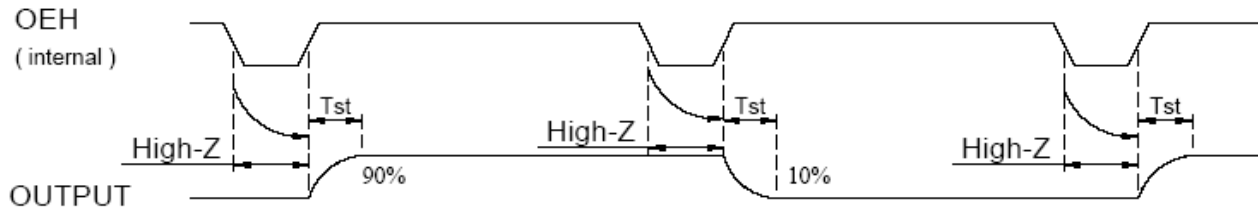

7.9. Analog video signal characteristics

PARAMETER	Symbol	Min.	Typ.	Max.	Unit
Video signal amplitude (VA, VB, VC)	V_{IAC}	-	3.81	-	V
	V_{IDC}	-	2.385	-	V

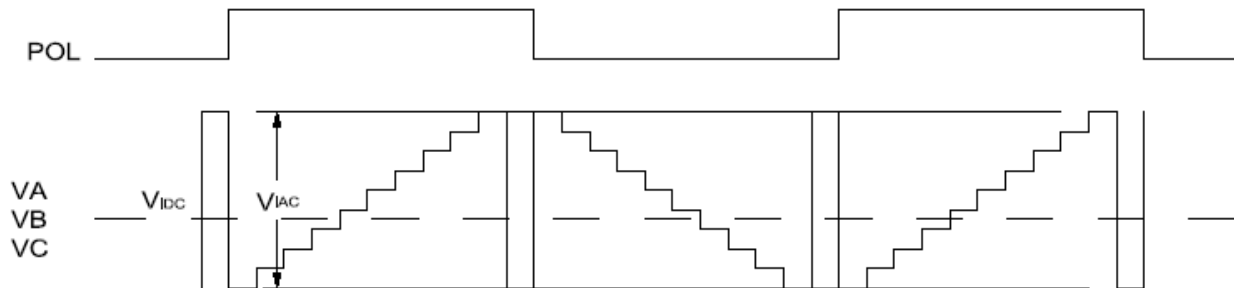
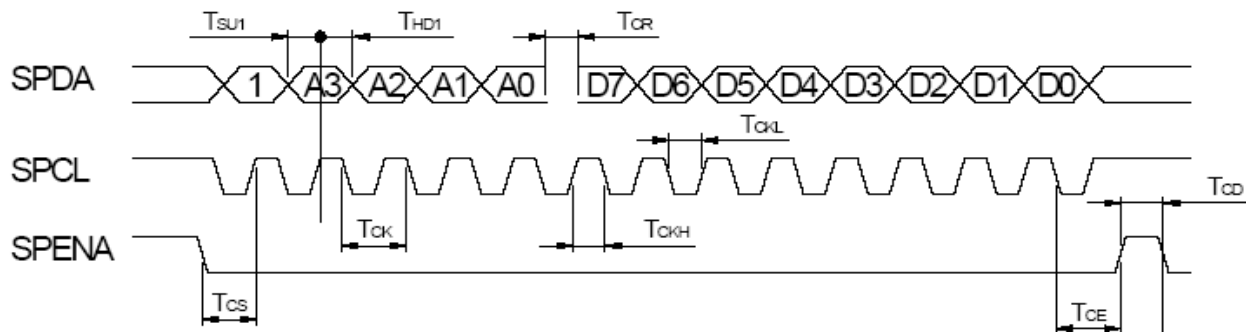

Fig. 4-(a) Horizontal timing

7.10. SPI timing characteristics

Parameter	Symbol	Min.	Typ.	Max.	Unit
SPCL period	T_{CK}	60	-	-	ns
SPCL high width	T_{CKH}	30	-	-	ns
SPCL low width	T_{CKL}	30	-	-	ns
Data setup time	T_{SU1}	12	-	-	ns
Data hold time	T_{HD1}	12	-	-	ns
SPENA to SPCK setup time	T_{CS}	20	-	-	ns
SPENA to SPDA hold time	T_{CE}	20	-	-	ns
SPENA high pulse width	T_{CD}	50	-	-	ns
SPDA output latency	T_{CR}	-	1/2	-	T_{CK}

● SPI "read" timing



● SPI "write" timing

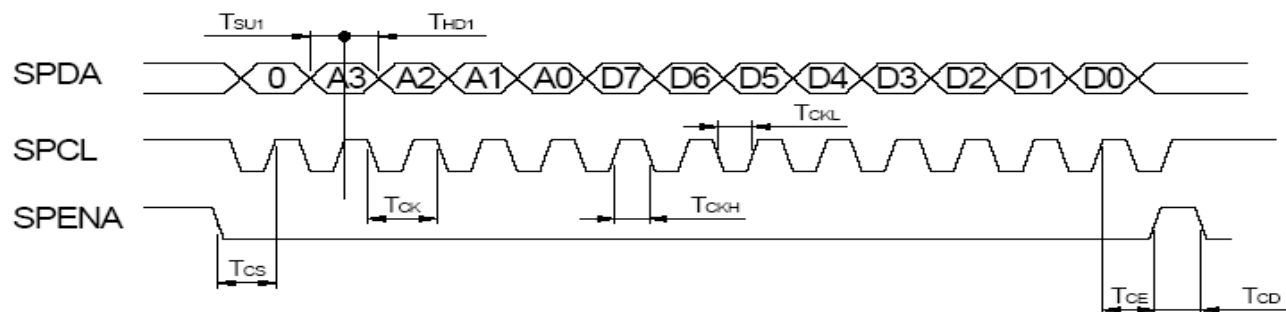

7.11. Gate Driver Timing Chart

Parameter	Symbol	Condition	Spec		Unit
			Min.	Max.	
Operation frequency	tCPV	-	5	-	us
CPV pulse width	tCPVH,tCPVL	50% duty cycle	2.5	-	
OE pulse width	twOE	-	1	-	
Data setup time	tsu	-	0.4	-	us
Data hold time	thd	-	0.7	-	
Output delay time	tpd1	CL=300pF	-	1	
Output delay time	tpd2	CL=300pF	-	0.8	
Output delay time	tpd3	CL=300pF	-	0.8	
Output delay time	tpd4	CL=300pF	-	10	

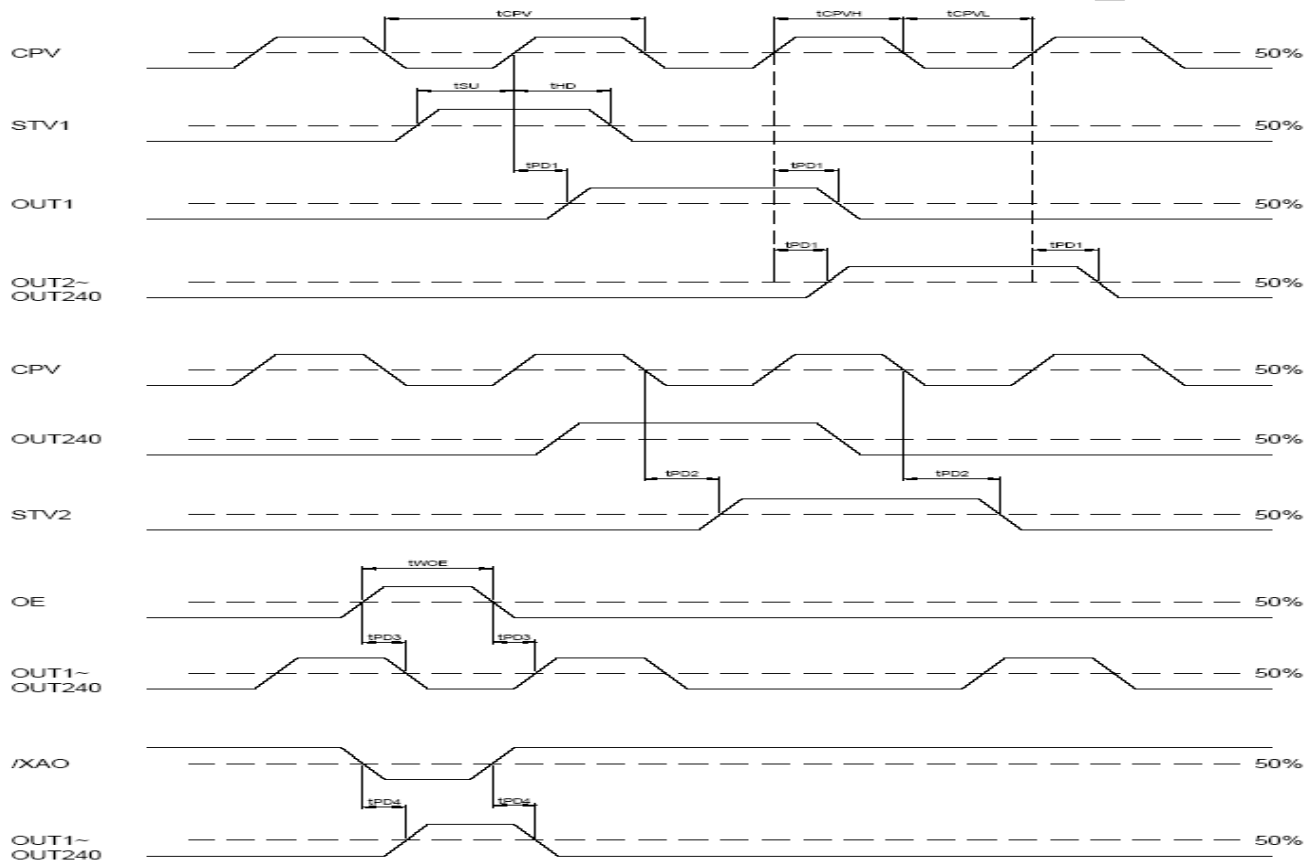

8. Optical Characteristics

Item	Symbol	Condition.	Min	Typ.	Max.	Unit	Remark
Response time	Tr+Tf	$\theta=0^\circ$ 、 $\phi=0^\circ$		25	-	.ms	Note 3
Contrast ratio	CR	At optimized viewing angle	-	300	-	-	Note 4
Color Chromaticity	White	Wx	$\theta=0^\circ$ 、 $\phi=0$	0.267	0.317	0.367	Note 2,6,7
		Wy		0.303	0.353	0.403	
Viewing angle (Gray Scale Inversion Direction)	Hor.	Θ_R	$CR \geq 10$	-	60	-	Deg.
		Θ_L		-	60	-	
	Ver.	Φ_T		-	70	-	
		Φ_B		-	70	-	
Brightness	-	-	400	500	-	cd/m ²	Center of display
Uniformity	(U)	-	75	-	-	%	Note 5

Ta=25±2°C, IL=140mA

Note 1: Definition of viewing angle range

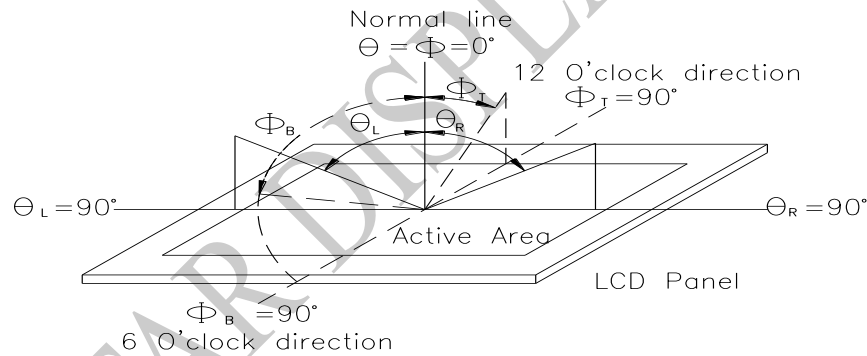

Fig. 8.1. Definition of viewing angle

Note 2: Test equipment setup:

After stabilizing and leaving the panel alone at a driven temperature for 10 minutes, the measurement should be executed. Measurement should be executed in a stable, windless, and dark room. Optical specifications are measured by Topcon BM-7 or BM-5 luminance meter 1.0° field of view at a distance of 50cm and normal direction.

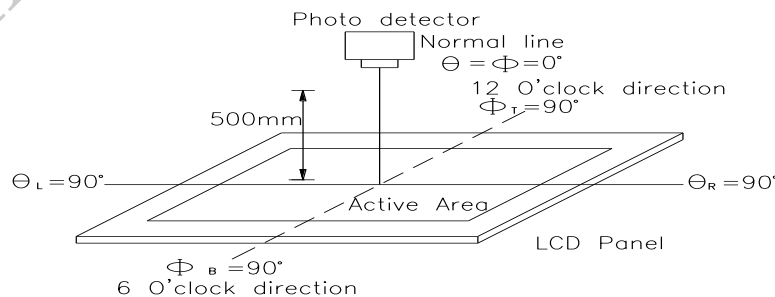
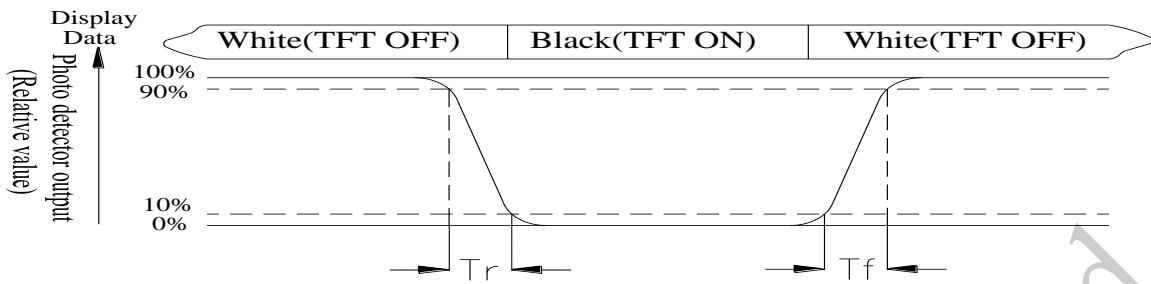

Fig. 8.2. Optical measurement system setup

Note 3: Definition of Response time:

The response time is defined as the LCD optical switching time interval between "White" state

and "Black" state. Rise time, T_r , is the time between photo detector output intensity changed from 90% to 10%. And fall time, T_f , is the time between photo detector output intensity changed from 10% to 90%



Note 4: Definition of contrast ratio:

The contrast ratio is defined as the following expression.

$$\text{Contrast ratio (CR)} = \frac{\text{Luminance measured when LCD on the "White" state}}{\text{Luminance measured when LCD on the "Black" state}}$$

Note 5: Definition of Luminance Uniformity

Active area is divided into 9 measuring areas (reference the picture in below). Every measuring point is placed at the center of each measuring area.

Luminance Uniformity (U) = $L_{\min}/L_{\max} \times 100\%$

L = Active area length

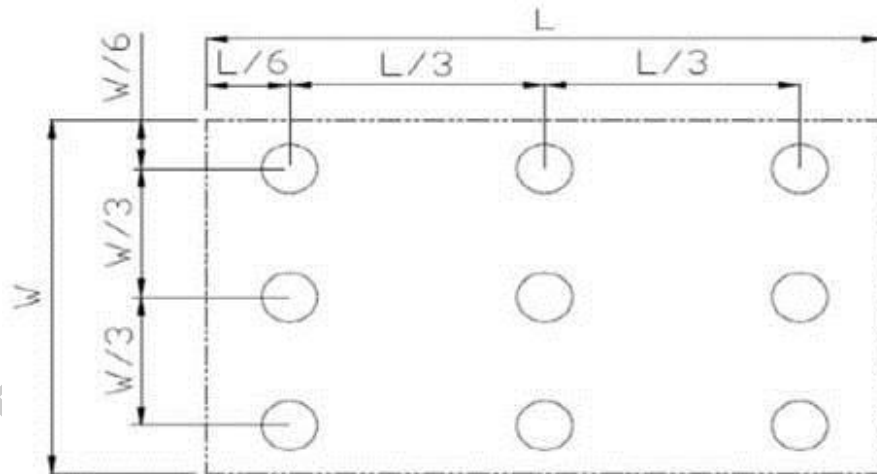

W = Active area width

Fig8.3. Definition of uniformity

Note 6: Definition of color chromaticity (CIE 1931)

Color coordinates measured at the center point of LCD

Note 7: Measured at the center area of the panel when all the input terminals of LCD panel are electrically opened.

9. Interface

9.1. LCM PIN Definition

Pin	Symbol	Function	Remark
1	IF1	Input data format control	Note1
2	IF2	Input data format control	Note1
3	POL	Polarity Signal connect to VCOM driving circuit.	Note3
4	RESET	Hardware reset	
5	SPENA	Chip select	Note2
6	SPCL	Serial Clock	Note2
7	SPDA	Serial Data	
8	B0	Blue Data bit	
9	B1	Blue Data bit	
10	B2	Blue Data bit	
11	B3	Blue Data bit	
12	B4	Blue Data bit	
13	B5	Blue Data bit	
14	B6	Blue Data bit	
15	B7	Blue Data bit	
16	G0	Green Data bit	
17	G1	Green Data bit	
18	G2	Green Data bit	
19	G3	Green Data bit	
20	G4	Green Data bit	
21	G5	Green Data bit	
22	G6	Green Data bit	
23	G7	Green Data bit	
24	R0	Red Data bit	
25	R1	Red Data bit	
26	R2	Red Data bit	
27	R3	Red Data bit	
28	R4	Red Data bit	
29	R5	Red Data bit	
30	R6	Red Data bit	

31	R7	Red Data bit	
32	Hsync	Horizontal synchronous signal	
33	Vsync	Vertical synchronous signal	
34	Data CLK	Dot data clock	
35	AVDD(analog)	Analog power: 4.5V~5.5V	
36	AVDD(analog)	Analog power: 4.5V~5.5V	
37	VCC(Digital)	Digital power: 3.2V~3.4V	
38	VCC(Digital)	Digital power: 3.2V~3.4V	
39	NPC	NTSC/PAL mode Auto detection result H:NTSC/L:PAL	
40	VGL	Gate off power	
41	VGL	Gate off power	
42	UD	Up/down selection	Note 5,6
43	VGH	Gate on power	
44	LRC	Shift direction of device internal shift register control.	Note 5,6
45	GND	System ground pin of the IC. Connect to system ground.	
46	VCOM	VCOM driving input	Note3
47	VCOM	VCOM driving input	
48	ENB	Signal to settle the horizontal display position	Note4
49	GND	System ground pin of the IC. Connect to system ground.	
50	GND	System ground pin of the IC. Connect to system ground.	

Note1: Control the input data format.

IF2,IF1	Input data format
L,L(default)	Serial RGB
L,H	Parallel RGB
H,L	CCIR601
H,H	CCIR656

Note 2: Pin 5、Pin 6 usually pull high.

Note 3: The polarity of VCOM (Pin 46,47) should be generated from POL (Pin 3).

Note 4: For digital RGB input data format, both SYNC mode and DE+SYNC mode are supported. If ENB signal is fixed low, SYNC mode is used. Otherwise, DE+SYNC mode is used.

Note 5: Selection of scanning mode

Setting of scan control input		Scanning direction
U/D	L/R	
L	H	Up to down, left to right
H	L	Down to up, right to left
L	L	Up to down, right to left
H	H	Down to up, left to right

Note 6: Definition of scanning direction Refer to the figure as below:



U/D=L, L/R=H

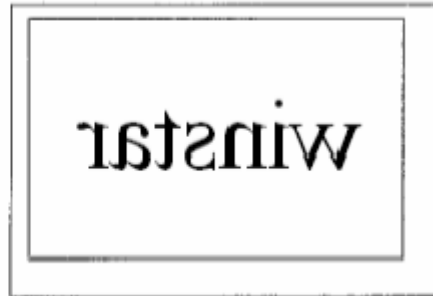

U/D=L, L/R=L

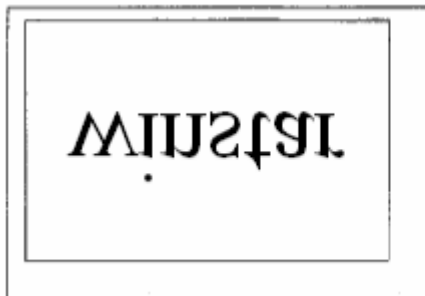

U/D=H, L/R=H

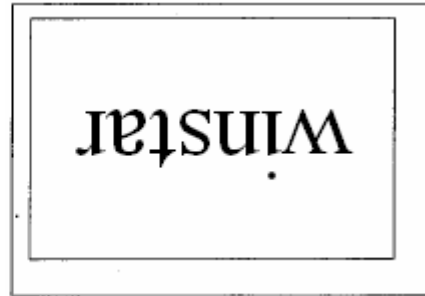

U/D=H, L/R=L

WINSTAR

10. Block Diagram

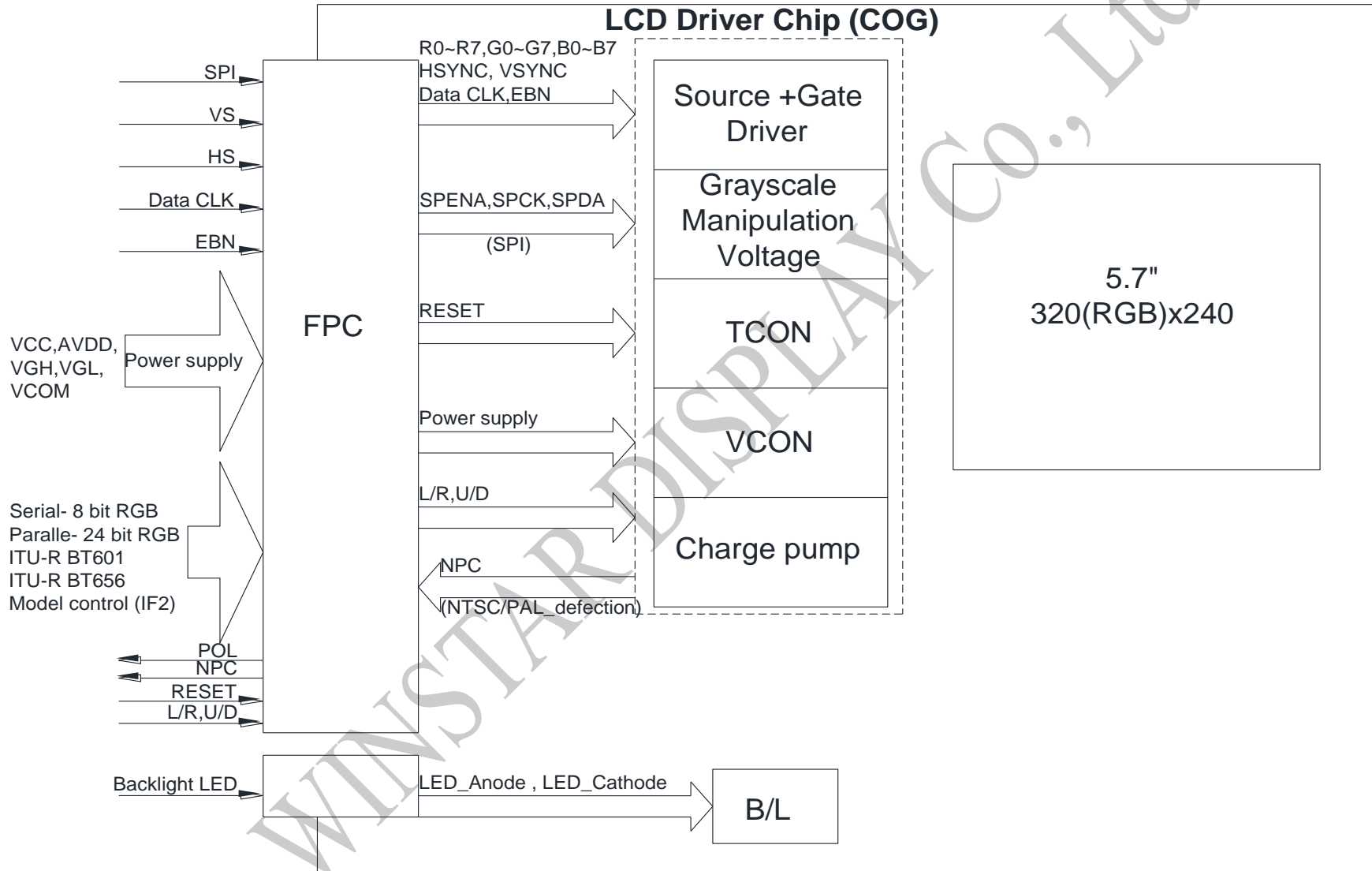

11. Reliability

Content of Reliability Test (Wide temperature, -20°C~70°C)

Environmental Test			
Test Item	Content of Test	Test Condition	Note
High Temperature storage	Endurance test applying the high storage temperature for a long time.	80°C 200hrs	2
Low Temperature storage	Endurance test applying the low storage temperature for a long time.	-30°C 200hrs	1,2
High Temperature Operation	Endurance test applying the electric stress (Voltage & Current) and the thermal stress to the element for a long time.	70°C 200hrs	—
Low Temperature Operation	Endurance test applying the electric stress under low temperature for a long time.	-20°C 200hrs	1
High Temperature/ Humidity Operation	The module should be allowed to stand at 60°C,90%RH max	60°C,90%RH 96hrs	1,2
Thermal shock resistance	The sample should be allowed stand the following 10 cycles of operation <div style="text-align: center;"> <p style="margin: 0;">-20°C 25°C 70°C</p> <p style="margin: 0;">30min 5min 30min</p> <p style="margin: 0;">1 cycle</p> </div>	-20°C/70°C 10 cycles	—
Vibration test	Endurance test applying the vibration during transportation and using.	Total fixed amplitude : 1.5mm Vibration Frequency : 10~55Hz One cycle 60 seconds to 3 directions of X,Y,Z for Each 15 minutes	3
Static electricity test	Endurance test applying the electric stress to the terminal.	VS=±600V(contact), ±800v(air), RS=330Ω CS=150pF 10 times	—

Note1: No dew condensation to be observed.

Note2: The function test shall be conducted after 4 hours storage at the normal Temperature and humidity after remove from the test chamber.

Note3: The packing have to including into the vibration testing.

12. Contour Drawing

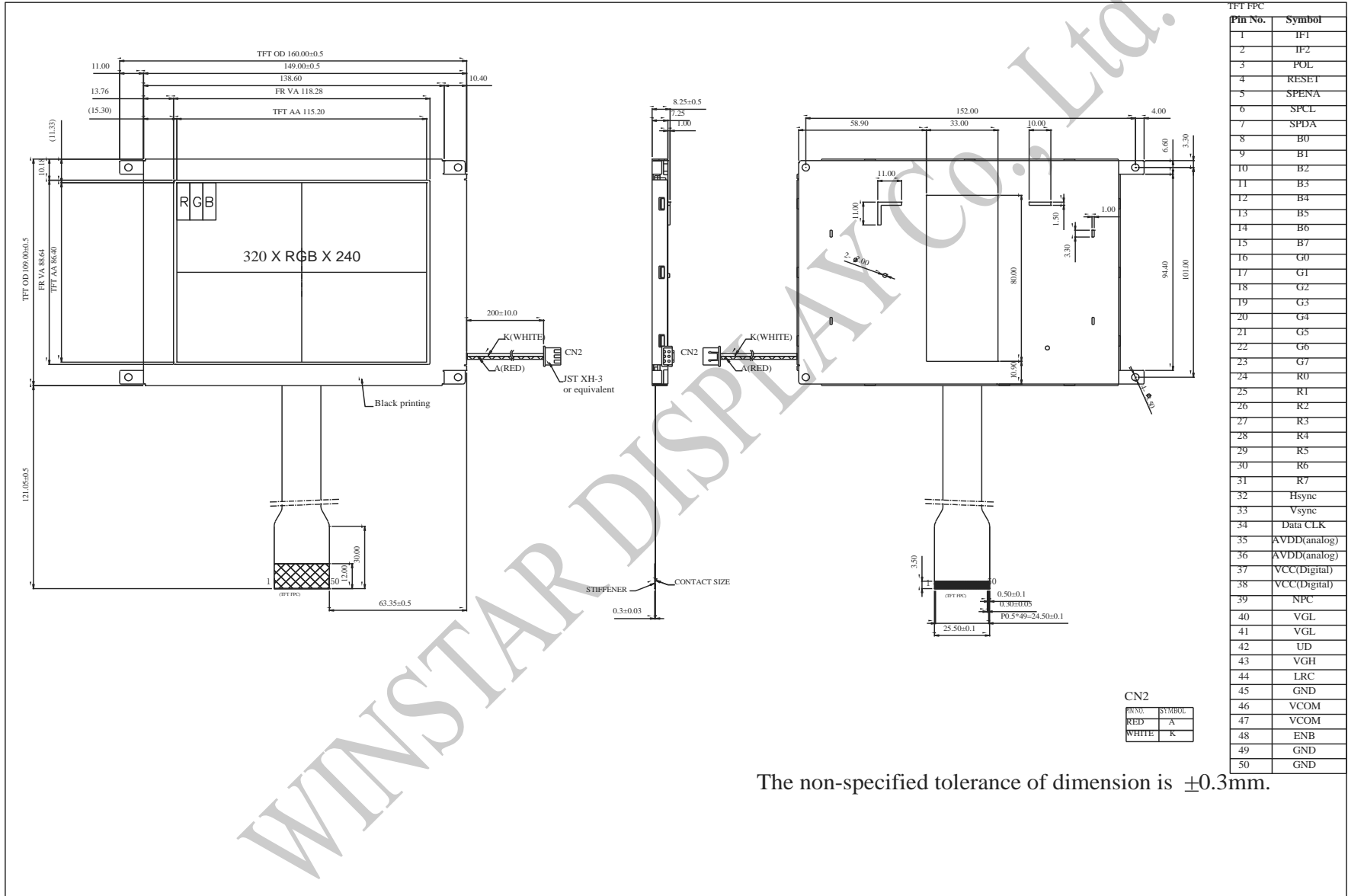

The non-specified tolerance of dimension is ±0.3mm.



1、Panel Specification :

- 1. Panel Type : Pass NG , _____
- 2. View Direction : Pass NG , _____
- 3. Numbers of Dots : Pass NG , _____
- 4. View Area : Pass NG , _____
- 5. Active Area : Pass NG , _____
- 6. Operating : Pass NG , _____
- 7. Storage Temperature : Pass NG , _____
- 8. Others : _____

2、Mechanical

- 1. PCB Size : Pass NG , _____
- 2. Frame Size : Pass NG , _____
- 3. Material of Frame : Pass NG , _____
- 4. Connector Position : Pass NG , _____
- 5. Fix Hole Position : Pass NG , _____
- 6. Backlight Position : Pass NG , _____
- 7. Thickness of PCB : Pass NG , _____
- 8. Height of Frame to PCB : Pass NG , _____
- 9. Height of Module : Pass NG , _____
- 10. Others : Pass NG , _____

3、Relative Hole Size :

- 1. Pitch of Connector : Pass NG , _____
- 2. Hole size of Connector : Pass NG , _____
- 3. Mounting Hole size : Pass NG , _____
- 4. Mounting Hole Type : Pass NG , _____
- 5. Others : Pass NG , _____

4、Backlight Specification :

- 1. B/L Type : Pass NG , _____
- 2. B/L Color : Pass NG , _____
- 3. B/L Driving Voltage (Reference for LED) : Pass NG , _____
- 4. B/L Driving Current : Pass NG , _____
- 5. Brightness of B/L : Pass NG , _____
- 6. B/L Solder Method : Pass NG , _____
- 7. Others : Pass NG , _____



Winstar Module Number : _____

Page: 2

5、Electronic Characteristics of Module :

- 1. Input Voltage : Pass NG , _____
- 2. Supply Current : Pass NG , _____
- 3. Driving Voltage for LCD : Pass NG , _____
- 4. Contrast for LCD : Pass NG , _____
- 5. B/L Driving Method : Pass NG , _____
- 6. Negative Voltage Output : Pass NG , _____
- 7. Interface Function : Pass NG , _____
- 8. LCD Uniformity : Pass NG , _____
- 9. ESD test : Pass NG , _____
- 10. Others : Pass NG , _____

6、Summary :

Sales signature : _____

Customer Signature : _____

Date : / / _____

