



WINSTAR Display Co.,Ltd.
華凌光電股份有限公司



Winstar Display Co., LTD

華凌光電股份有限公司



WEB: <https://www.winstar.com.tw> E-mail: sales@winstar.com.tw

SPECIFICATION

CUSTOMER : _____

MODULE NO.: WF57A3TIGCDNNO#

| | |
|---|--|
| <p>APPROVED BY:</p> <p>(FOR CUSTOMER USE ONLY)</p> | <p>PCB VERSION: _____</p> <p>DATA: _____</p> |
|---|--|

| SALES BY | APPROVED BY | CHECKED BY | PREPARED BY |
|--------------------------------|-------------|------------|-------------|
| | | | 葉虹蘭 |
| ISSUED DATE: 2023/02/03 | | | |

TFT Display Inspection Specification: <https://www.winstar.com.tw/technology/download.html>

Precaution in use of TFT module: <https://www.winstar.com.tw/technology/download/declaration.html>



Winstar Display Co., LTD
華凌光電股份有限公司

MODLE NO :

RECORDS OF REVISION

DOC. FIRST ISSUE

| VERSION | DATE | REVISED PAGE NO. | SUMMARY |
|---------|------------|---------------------|-------------|
| 0 | 2023/02/03 | | First issue |

WINSTAR DISPLAY Co., Ltd.

Contents

1.Module Classification Information

2.Summary

3.General Specifications

4.Absolute Maximum Ratings

5.Electrical Characteristics

6.DC Characteristics

7.AC Characteristics

8.Optical Characteristics

9.Interface

10.Block Diagram

11.Reliability

12.Contour Drawing

13.Other

WINSTAR DISPLAY Co., Ltd.

1.Module Classification Information

W F 57 A3 T I G C D N N 0 #
 ① ② ③ ④ ⑤ ⑥ ⑦ ⑧ ⑨ ⑩ ⑪ ⑫ ⑬

| | | | | | | | | | | | | |
|---|---|---|--|---------|---|---|--|------------------------------------|---------------|--------------------------------|---|---------|
| ① | Brand : WINSTAR DISPLAY CORPORATION | | | | | | | | | | | |
| ② | Display Type : F→TFT Type, J→Custom TFT | | | | | | | | | | | |
| ③ | Display Size : 5.7" TFT | | | | | | | | | | | |
| ④ | Model serials no. | | | | | | | | | | | |
| ⑤ | Backlight Type : | F→CCFL, White S→LED, High Light White | | | | | T→LED, White Z→Nichia LED, White | | | | | |
| ⑥ | LCD Polarize Type/ Temperature range/ Gray Scale Inversion Direction | A→Transmissive, N.T, IPS TFT C→Transmissive, N. T, 6:00 ; F→Transmissive, N.T,12:00 ; I→Transmissive, W. T, 6:00 K→Transflective, W.T,12:00 L→Transmissive, W.T,12:00 N→Transmissive, Super W.T, 6:00 | | | | | Q→Transmissive, Super W.T, 12:00 R→Transmissive, Super W.T, O-TFT V→Transmissive, Super W.T, VA TFT W→Transmissive, Super W.T, IPS TFT X→Transmissive, W.T, VA TFT Y→Transmissive, W.T, IPS TFT Z→Transmissive, W.T, O-TFT | | | | | |
| ⑦ | A : TFT LCD B : TFT+SCREW HOLES+CONTROL BOARD C : TFT+ SCREW HOLES +A/D BOARD D : TFT+ SCREW HOLES +A/D BOARD+CONTROL BOARD E : TFT+ SCREW HOLES +POWER BOARD | | | | | F : TFT+CONTROL BOARD G : TFT+ SCREW HOLES H : TFT+D/V BOARD I : TFT+ SCREW HOLES +D/V BOARD J : TFT+POWER BD | | | | | | |
| ⑧ | Resolution: | | | | | | | | | | | |
| | A | 128160 | B | 320234 | C | 320240 | D | 480234 | E | 480272 | F | 640480 |
| | G | 800480 | H | 1024600 | I | 320480 | J | 240320 | K | 800600 | L | 240400 |
| | M | 1024768 | N | 128128 | P | 1280800 | Q | 480800 | R | 640320 | S | 480128 |
| | T | 800320 | U | 8001280 | V | 176220 | W | 1280398 | X | 1024250 | Y | 1920720 |
| | Z | 800200 | 2 | 1024324 | 3 | 7201280 | 4 | 19201200 | 5 | 1366768 | 6 | 1280320 |
| ⑨ | D: Digital L : LVDS M:MIPI | | | | | | | | | | | |
| ⑩ | Interface: | | | | | | | | | | | |
| | N | Without control board | | | A | 8Bit | | B | 16Bit | | H | HDMI |
| | I | I2C Interface | | | R | RS232 | | S | SPI Interface | | U | USB |
| ⑪ | TS: | | | | | | | | | | | |
| | N | Without TS | | | T | Resistive touch panel | | | C | Capacitive touch panel (G-F-F) | | |
| | G | Capacitive touch panel (G-G) | | | | | C1 | Capacitive touch panel (G-F-F)+OCA | | | | |
| | C2 | Capacitive touch panel (G-F-F)+OCR | | | | | G1 | Capacitive touch panel (G-G)+OCA | | | | |
| | G2 | Capacitive touch panel (G-G)+OCR | | | | | B | CTP+GG+USB | | | | |
| ⑫ | Version: X:Raspberry pi | | | | | | | | | | | |
| ⑬ | Special Code | | #:Fit in with ROHS directive regulations | | | | | | | | | |

| | | |
|--|--|--|
| | | |
|--|--|--|

WINSTAR DISPLAY Co., Ltd.

2.Summary

TFT 5.7” is a TN transmissive type color active matrix TFT liquid crystal display that use amorphous silicon TFT as switching devices. This module is a composed of a TFT_LCD module, It is usually designed for industrial application and this module follows RoHs.

WINSTAR DISPLAY Co., Ltd.

3. General Specifications

| Item | Dimension | Unit |
|--------------------------------|-----------------------------------|------|
| Size | 5.7 | inch |
| Dot Matrix | 320 x RGBx240(TFT) | dots |
| Module dimension | 141.12(W) x 101.55(H) x 6.05(D) | mm |
| Active area | 115.2 x 86.40 | mm |
| Dot pitch | 0.12 x 0.36 | mm |
| LCD type | TFT, Normally White, Transmissive | |
| TFT Driver IC | HX8218 +HX8615 or Equivalent | |
| TFT Interface | 24-bit RGB | |
| View Direction | 12 o'clock | |
| Gray Scale Inversion Direction | 6 o'clock | |
| Aspect Ratio | 4:3 | |
| Backlight Type | LED, Normally White | |
| With /Without TP | Without TP | |
| Surface | Glare | |

*Color tone slight changed by temperature and driving voltage.

4. Absolute Maximum Ratings

| Item | Symbol | Min | Typ | Max | Unit |
|-----------------------|--------|-----|-----|-----|------|
| Operating Temperature | TOP | -20 | — | +70 | °C |
| Storage Temperature | TST | -30 | — | +80 | °C |

Note: Device is subject to be damaged permanently if stresses beyond those absolute maximum ratings listed above

1. Temp. $\leq 60^{\circ}\text{C}$, 90% RH MAX. Temp. $> 60^{\circ}\text{C}$, Absolute humidity shall be less than 90% RH at 60°C

WINSTAR DISPLAY Co., Ltd

5. Electrical Characteristics

5.1. Operating conditions:

| Item | Symbol | Condition | Min | Typ | Max | Unit |
|--------------------------|--------|-----------|-----|-----|-----|------|
| Supply Voltage For Logic | VCC | — | 3.0 | 3.3 | 3.6 | V |
| Supply Current | ICC | VCC=3.3V | — | 230 | 345 | mA |

5.2. LED driving conditions

| Parameter | Symbol | Min. | Typ. | Max. | Unit | Remark |
|-------------------|--------|------|--------|------|------|------------|
| LED current | — | — | 140 | — | mA | — |
| Power Consumption | — | 1204 | — | 1470 | mW | — |
| LED voltage | VBL+ | 8.6 | — | 10.5 | V | Note 1 |
| LED Life Time | — | — | 50,000 | — | Hr | Note 2,3,4 |

Note 1 : There are 1 Groups LED

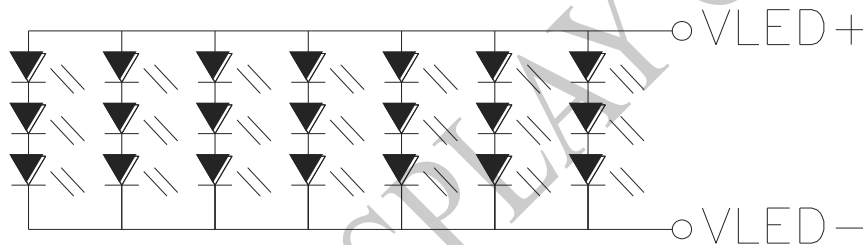

Backlight LED Circuit

Note 2 : $T_a = 25\text{ }^\circ\text{C}$

Note 3 : Brightness to be decreased to 50% of the initial value

Note 4 : The single LED lamp case.

6.DC CHARATERISTICS

| Parameter | Symbol | Rating | | | Unit | Condition |
|--------------------------|----------|--------|-----|--------|------|-----------|
| | | Min | Typ | Max | | |
| Low level input voltage | V_{IL} | 0 | - | 0.3VCC | V | |
| High level input voltage | V_{IH} | 0.7VCC | - | VCC | V | |

WINSTAR DISPLAY Co., Ltd.

7.AC Characteristics

7.1. 24-bits parallel RGB Interface AC Timing Characteristics

| Signal | Item | Symbol | Min. | Typ. | Max. | Unit | |
|--------|----------------|--------|------|------|-------|------|------|
| Dclk | Frequency | Dclk | - | 6.4 | - | MHZ | |
| | High time | Tch | - | 78 | - | ns | |
| | Low time | Tcl | - | 78 | - | ns | |
| Data | Setup time | Tds | 12 | - | - | ns | |
| | Hold time | Tdh | 12 | - | - | ns | |
| Hsync | Period | TH | - | 408 | - | DCLK | |
| | Pulse Width | Thp | - | 30 | - | DCLK | |
| | Back-Porch | Thb | - | 38 | - | DCLK | |
| | Display Period | Thd | - | 320 | - | DCLK | |
| | Front-Porch | Thf | - | 20 | - | DCLK | |
| Vsync | Period | NTSC | TV | - | 262.5 | - | DCLK |
| | | PAL | | - | 312.5 | - | |
| | Pulse Width | | Tvp | 1 | 3 | 5 | TH |
| | Back-Porch | NTSC | Tvb | - | 15 | - | TH |
| | | PAL | | - | 23 | - | |
| | Display Period | | Tvd | - | 240 | - | TH |
| | Front-Porch | NTSC | Tvf | - | 4.5 | - | TH |
| PAL | | - | | 46.5 | - | | |

AC Timing Diagrams

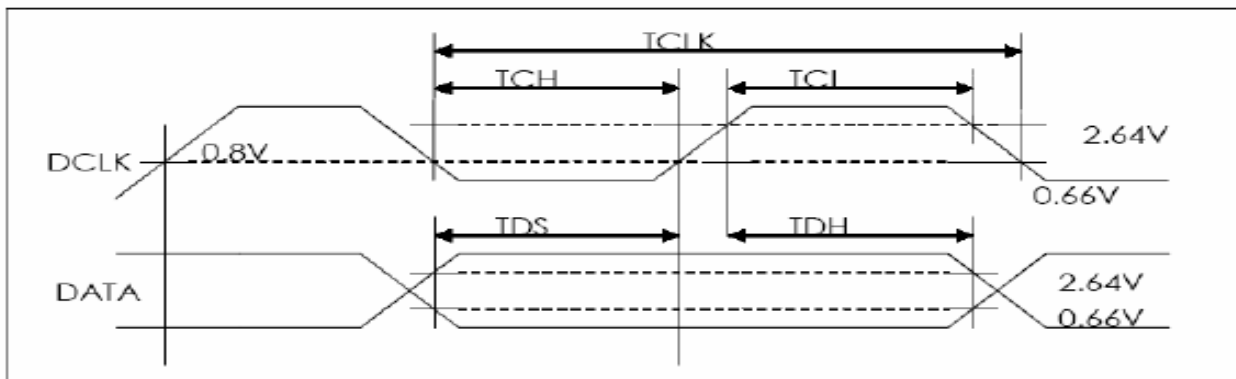
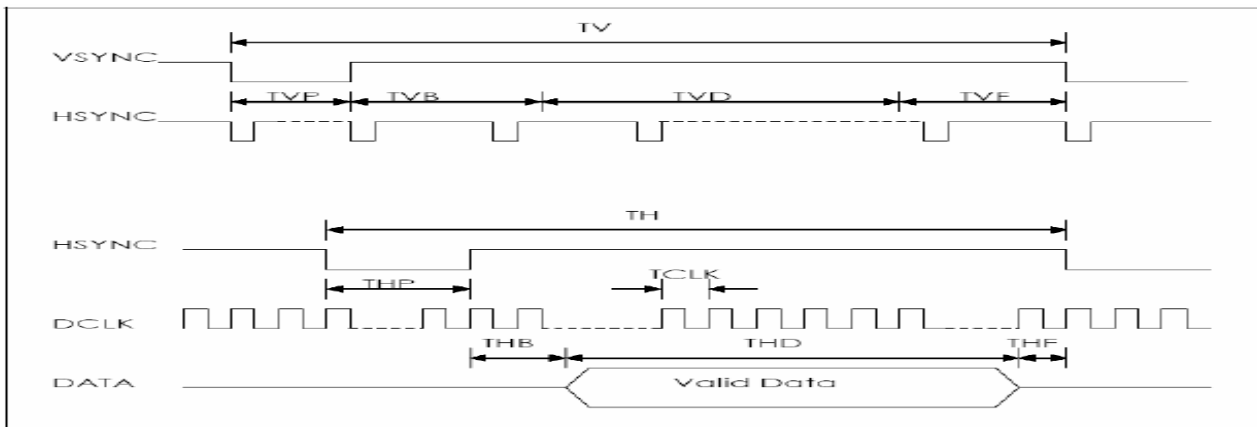

8. Optical Characteristics

| Item | Symbol | Condition. | Min | Typ. | Max. | Unit | Remark | |
|--|--------|-----------------------------------|-----------------------------|-------|-------|-------------------|-------------------|--------|
| Response time | Tr+ Tf | $\theta=0^\circ$ 、 $\phi=0^\circ$ | - | 25 | - | .ms | Note 3,5 | |
| Contrast ratio | CR | At optimized viewing angle | - | 300 | - | - | Note 4,5 | |
| Color Chromaticity | White | Wx | $\theta=0^\circ$ 、 $\phi=0$ | 0.267 | 0.317 | 0.367 | Note 2,6,7 | |
| | | Wy | | 0.303 | 0.353 | 0.403 | | |
| Viewing angle (Gray Scale Inversion Direction) | Hor. | Θ_R | CR \geq 10 | - | 60 | - | Deg. | Note 1 |
| | | Θ_L | | - | 60 | - | | |
| | Ver. | Φ_T | | - | 70 | - | | |
| | | Φ_B | | - | 70 | - | | |
| Brightness | - | - | 800 | 900 | - | cd/m ² | Center of display | |
| Uniformity | (U) | - | 75 | - | - | % | Note 5 | |

Ta=25±2°C, IL=140mA

Note 1: Definition of viewing angle range

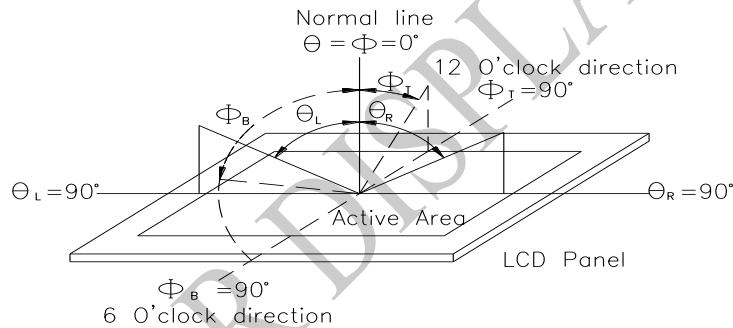

Fig.8.1. Definition of viewing angle

Note 2: Test equipment setup:

After stabilizing and leaving the panel alone at a driven temperature for 10 minutes, the measurement should be executed. Measurement should be executed in a stable, windless, and dark room. Optical specifications are measured by Topcon BM-7orBM-5 luminance meter 1.0° field of view at a distance of 50cm and normal direction.

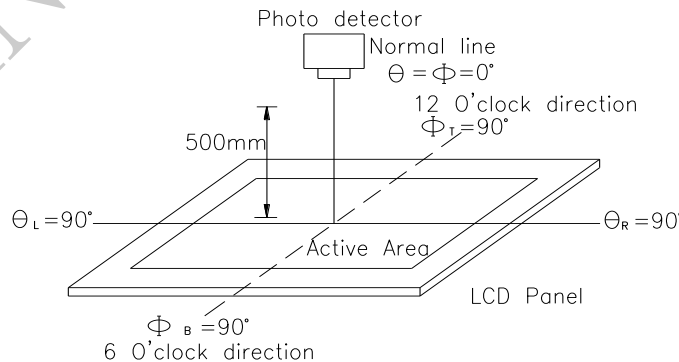
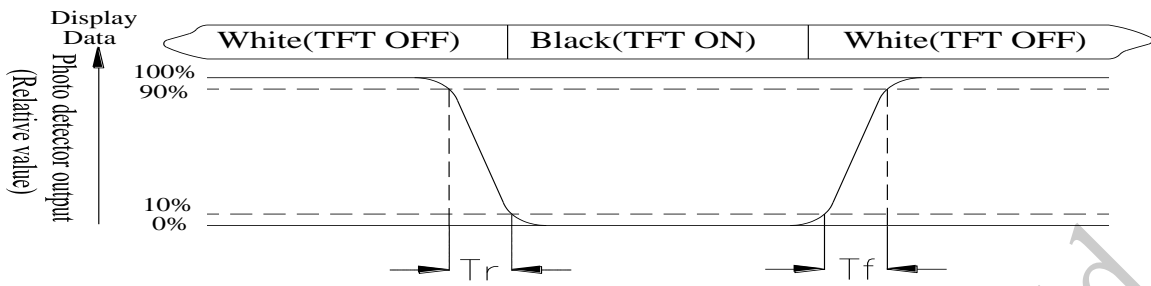

Fig. 8.2. Optical measurement system setup

Note 3: Definition of Response time:

The response time is defined as the LCD optical switching time interval between “White” state

and "Black" state. Rise time, T_r , is the time between photo detector output intensity changed from 90% to 10%. And fall time, T_f , is the time between photo detector output intensity changed from 10% to 90%



Note 4: Definition of contrast ratio:

The contrast ratio is defined as the following expression.

$$\text{Contrast ratio (CR)} = \frac{\text{Luminance measured when LCD on the "White" state}}{\text{Luminance measured when LCD on the "Black" state}}$$

Note 5: Definition of Luminance Uniformity

Active area is divided into 9 measuring areas (reference the picture in below). Every measuring point is placed at the center of each measuring area.

$$\text{Luminance Uniformity (U)} = \text{Lmin/Lmax} \times 100\%$$

L = Active area length

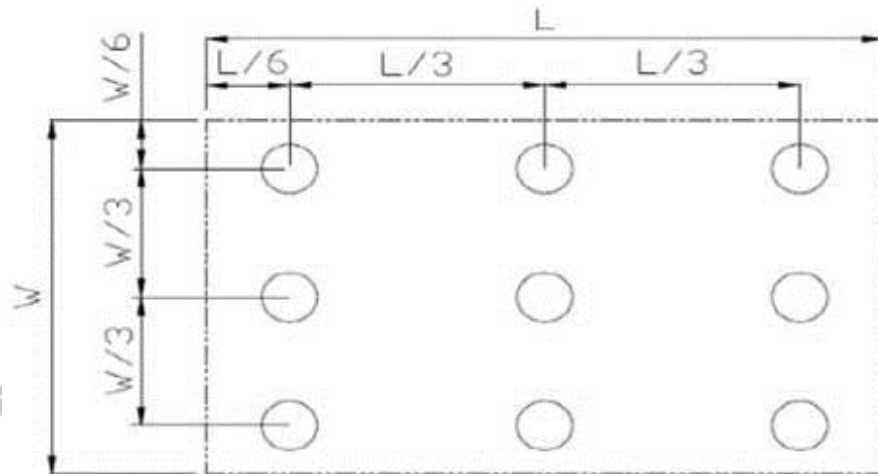

W = Active area width

Fig8.3. Definition of uniformity

Note 6: Definition of color chromaticity (CIE 1931)

Color coordinates measured at the center point of LCD

Note 7: Measured at the center area of the panel when all the input terminals of LCD panel are electrically opened.

9. Interface

9.1. LCM PIN Definition

| Pin | Symbol | Function | Remark |
|-----|--------|--|--------|
| 1 | NC | No connection | |
| 2 | NC | No connection | |
| 3 | GND | System ground pin of the IC. Connect to system ground. | |
| 4 | VCC | Power Supply | |
| 5 | R0 | Red Data bit(LSB) | |
| 6 | R1 | Red Data bit | |
| 7 | R2 | Red Data bit | |
| 8 | R3 | Red Data bit | |
| 9 | R4 | Red Data bit | |
| 10 | R5 | Red Data bit | |
| 11 | R6 | Red Data bit | |
| 12 | R7 | Red Data bit (MSB) | |
| 13 | G0 | Green Data bit(LSB) | |
| 14 | G1 | Green Data bit | |
| 15 | G2 | Green Data bit | |
| 16 | G3 | Green Data bit | |
| 17 | G4 | Green Data bit | |
| 18 | G5 | Green Data bit | |
| 19 | G6 | Green Data bit | |
| 20 | G7 | Green Data bit (MSB) | |
| 21 | B0 | Blue Data bit(LSB) | |
| 22 | B1 | Blue Data bit | |
| 23 | B2 | Blue Data bit | |
| 24 | B3 | Blue Data bit | |
| 25 | B4 | Blue Data bit | |
| 26 | B5 | Blue Data bit | |
| 27 | B6 | Blue Data bit | |
| 28 | B7 | Blue Data bit (MSB) | |
| 29 | GND | System ground pin of the IC. Connect to system ground. | |
| 30 | CLK | Dot data clock | |

| | | | |
|-------|-------|--|---------|
| 31 | R/L | Shift direction of device internal shift register control. | Note2,3 |
| 32 | Hsync | Horizontal sync signal | Note1 |
| 33 | Vsync | Vertical sync signal | Note1 |
| 34 | DE | Data Enable signal | Note1 |
| 35 | U/D | Up/down selection | Note2,3 |
| 36 | RESET | Hardware reset | |
| 37-40 | NC | No connection | |

For digital 24Bit RGB input data format, both SYNC mode and DE mode are supported. If DE signal is fixed low, SYNC mode is used. Otherwise, DE mode is used. Suggest used SYNC mode!!

| Mode | D[23:16] | D[15:8] | D[7:0] | IHS | IVS | DEN |
|------------|----------|---------|--------|----------------------|----------------------|--------------------------------------|
| 24 bit RGB | R[7:0] | G[7:0] | B[7:0] | Hsync | Vsync | DE signal is fixed low for SYNC mode |
| | | | | Floating if not used | Floating if not used | DE for DE Mode |

Note 2: Selection of scanning mode

| Setting of scan control input | | Scanning direction |
|-------------------------------|-----|---------------------------|
| U/D | R/L | |
| GND | VCC | Up to down, left to right |
| VCC | GND | Down to up, right to left |
| GND | GND | Up to down, right to left |
| VCC | VCC | Down to up, left to right |

Note 3: Definition of scanning direction. Refer to the figure as below:

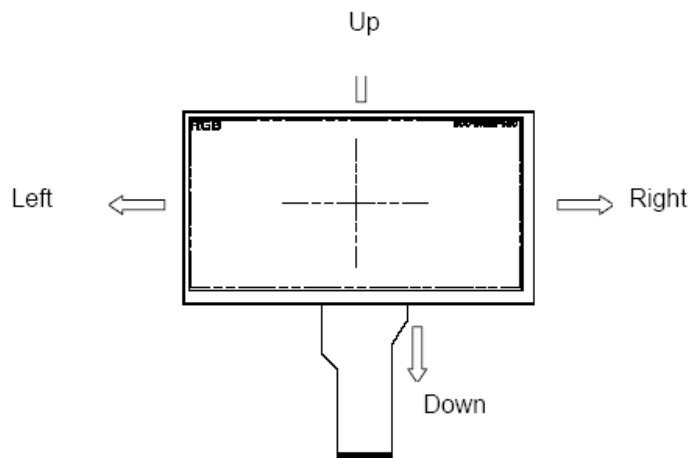

10. Block Diagram

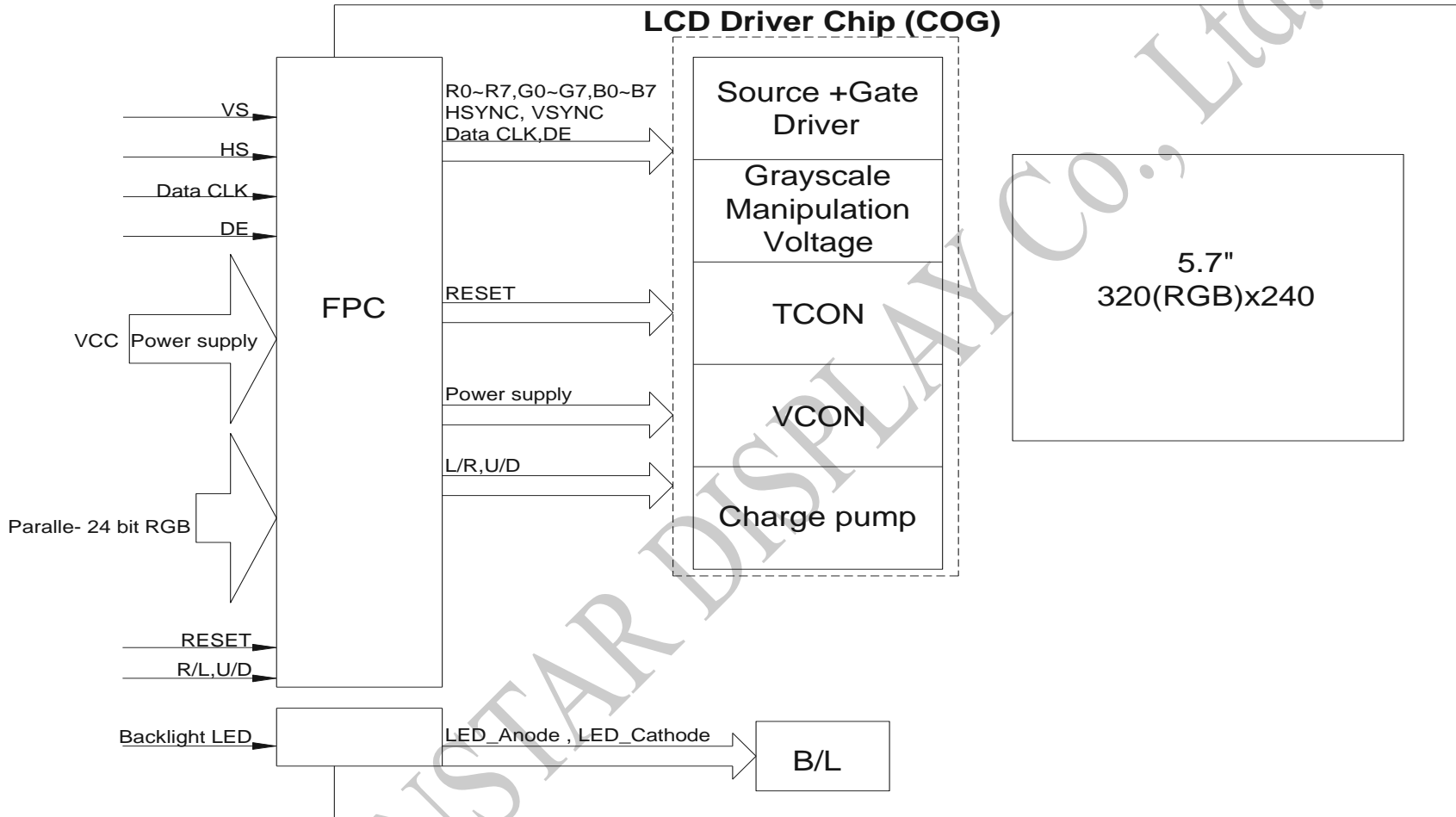

11. Reliability

Content of Reliability Test (Wide temperature, -20°C~70°C)

| Environmental Test | | | |
|---|--|--|------|
| Test Item | Content of Test | Test Condition | Note |
| High Temperature storage | Endurance test applying the high storage temperature for a long time. | 80°C 200hrs | 2 |
| Low Temperature storage | Endurance test applying the low storage temperature for a long time. | -30°C 200hrs | 1,2 |
| High Temperature Operation | Endurance test applying the electric stress (Voltage & Current) and the thermal stress to the element for a long time. | 70°C 200hrs | — |
| Low Temperature Operation | Endurance test applying the electric stress under low temperature for a long time. | -20°C 200hrs | 1 |
| High Temperature/ Humidity Operation | The module should be allowed to stand at 60°C,90%RH max | 60°C,90%RH 96hrs | 1,2 |
| Thermal shock resistance | The sample should be allowed stand the following 10 cycles of operation <div style="text-align: center;"> <p style="margin: 0;">-20°C 25°C 70°C</p> <p style="margin: 0;">30min 5min 30min</p> <p style="margin: 0;">1 cycle</p> </div> | -20°C/70°C 10 cycles | — |
| Vibration test | Endurance test applying the vibration during transportation and using. | Total fixed amplitude : 1.5mm Vibration Frequency : 10~55Hz One cycle 60 seconds to 3 directions of X,Y,Z for Each 15 minutes | 3 |
| Static electricity test | Endurance test applying the electric stress to the terminal. | VS=±600V(contact), ±800v(air), RS=330Ω CS=150pF 10 times | — |

Note1: No dew condensation to be observed.

Note2: The function test shall be conducted after 4 hours storage at the normal Temperature and humidity after remove from the test chamber.

Note3: The packing have to including into the vibration testing.

12. Contour Drawing

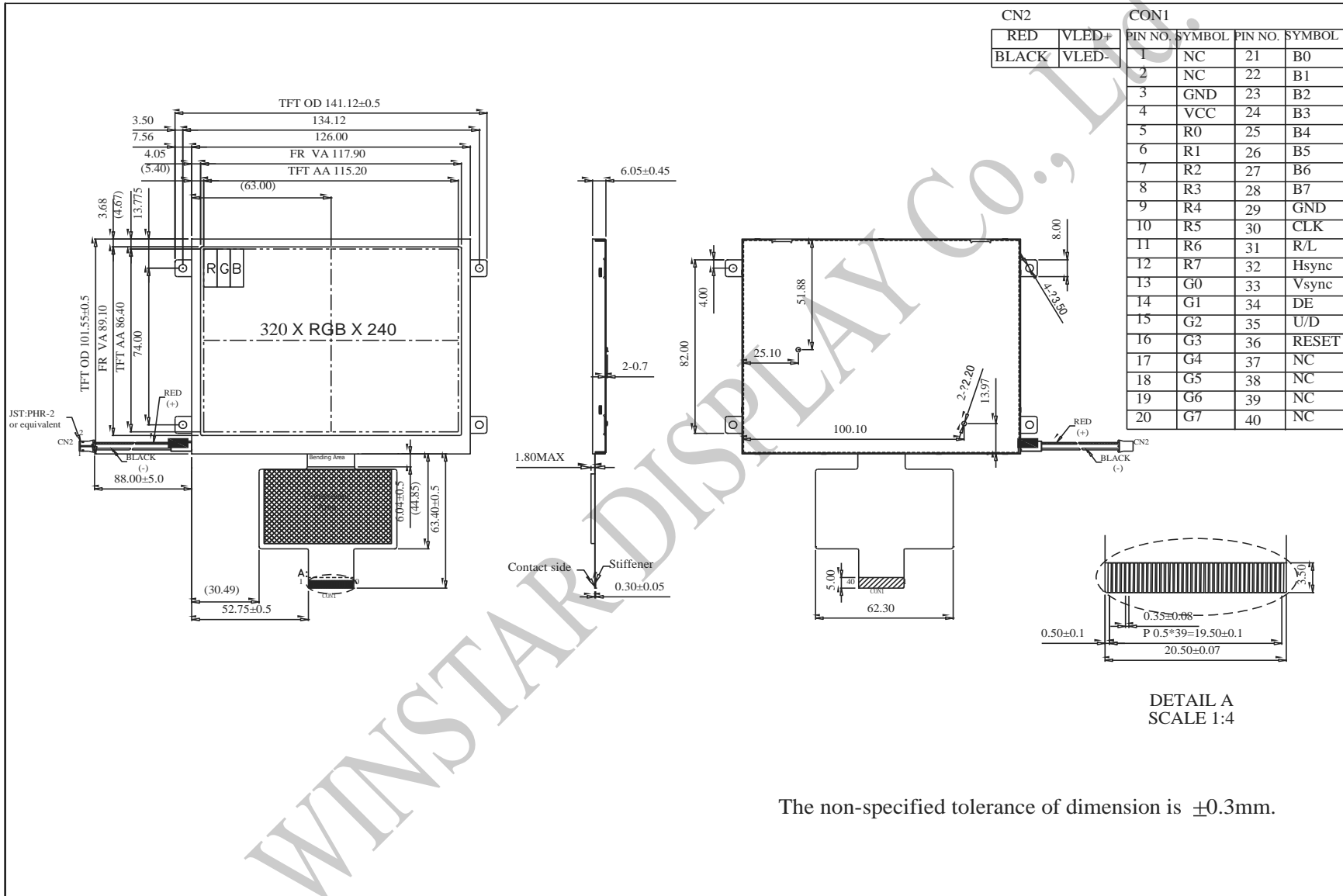

The non-specified tolerance of dimension is $\pm 0.3\text{mm}$.



1、Panel Specification :

- 1. Panel Type : Pass NG , _____
- 2. View Direction : Pass NG , _____
- 3. Numbers of Dots : Pass NG , _____
- 4. View Area : Pass NG , _____
- 5. Active Area : Pass NG , _____
- 6. Operating : Pass NG , _____
- 7. Storage Temperature : Pass NG , _____
- 8. Others : _____

2、Mechanical

- 1. PCB Size : Pass NG , _____
- 2. Frame Size : Pass NG , _____
- 3. Material of Frame : Pass NG , _____
- 4. Connector Position : Pass NG , _____
- 5. Fix Hole Position : Pass NG , _____
- 6. Backlight Position : Pass NG , _____
- 7. Thickness of PCB : Pass NG , _____
- 8. Height of Frame to PCB : Pass NG , _____
- 9. Height of Module : Pass NG , _____
- 10. Others : Pass NG , _____

3、Relative Hole Size :

- 1. Pitch of Connector : Pass NG , _____
- 2. Hole size of Connector : Pass NG , _____
- 3. Mounting Hole size : Pass NG , _____
- 4. Mounting Hole Type : Pass NG , _____
- 5. Others : Pass NG , _____

4、Backlight Specification :

- 1. B/L Type : Pass NG , _____
- 2. B/L Color : Pass NG , _____
- 3. B/L Driving Voltage (Reference for LED) : Pass NG , _____
- 4. B/L Driving Current : Pass NG , _____
- 5. Brightness of B/L : Pass NG , _____
- 6. B/L Solder Method : Pass NG , _____
- 7. Others : Pass NG , _____



Winstar Module Number : _____

Page: 2

5、Electronic Characteristics of Module :

- 1. Input Voltage : Pass NG , _____
- 2. Supply Current : Pass NG , _____
- 3. Driving Voltage for LCD : Pass NG , _____
- 4. Contrast for LCD : Pass NG , _____
- 5. B/L Driving Method : Pass NG , _____
- 6. Negative Voltage Output : Pass NG , _____
- 7. Interface Function : Pass NG , _____
- 8. LCD Uniformity : Pass NG , _____
- 9. ESD test : Pass NG , _____
- 10. Others : Pass NG , _____

6、Summary :

Sales signature : _____

Customer Signature : _____

Date : / / _____

