



**WINSTAR Display Co.,Ltd.**  
**華凌光電股份有限公司**



# Winstar Display Co., LTD

## 華凌光電股份有限公司



WEB: <https://www.winstar.com.tw> E-mail: sales@winstar.com.tw

### SPECIFICATION

**CUSTOMER :** \_\_\_\_\_

**MODULE NO.:** WF0200BTYAJDNG10#

<b>APPROVED BY:</b> ( FOR CUSTOMER USE ONLY )	<b>PCB VERSION:</b>	<b>DATA:</b>
--------------------------------------------------	---------------------	--------------

SALES BY	APPROVED BY	CHECKED BY	PREPARED BY
			周园园
<b>ISSUED DATE: 2022/08/24</b>			

TFT Display Inspection Specification: <https://www.winstar.com.tw/technology/download.html>

Precaution in use of TFT module: <https://www.winstar.com.tw/technology/download/declaration.html>



**Winstar Display Co., LTD**  
華凌光電股份有限公司

MODLE NO :

**RECORDS OF REVISION**

**DOC. FIRST ISSUE**

VERSION	DATE	REVISED PAGE NO.	SUMMARY
0	2022/06/09		First issue
A	2022/06/30		Modify LCD type
B	2022/08/24		Modify Contour Drawing

WINSTAR DISPLAY CO., LTD.

# Contents

1.Module Classification Information

2.Summary

3.General Specifications

4.Absolute Maximum Ratings

5.Electrical Characteristics

6.DC Characteristics

7.AC Characteristics

8.Optical Characteristics

9.Interface

10.Block Diagram

11.Reliability

12.Touch Panel Information

13.Contour Drawing

14.Initial Code For Reference

15.Other

# 1.Module Classification Information

W F 0200 B T Y A J D N G 1 0#  
 ① ② ③ ④ ⑤ ⑥ ⑦ ⑧ ⑨ ⑩ ⑪ ⑫ ⑬

①	Brand : WINSTAR DISPLAY CORPORATION											
②	Display Type : F→TFT Type, J→Custom TFT											
③	Display Size : 2.0" TFT											
④	Model serials no.											
⑤	Backlight Type :	F→CCFL, White S→LED, High Light White					T→LED, White Z→Nichia LED, White					
⑥	LCD Polarize Type/ Temperature range/ Gray Scale Inversion Direction	A→Transmissive, N.T, IPS TFT C→Transmissive, N. T, 6:00 ; F→Transmissive, N.T,12:00 ; I→Transmissive, W. T, 6:00 K→Transflective, W.T,12:00 L→Transmissive, W.T,12:00 N→Transmissive, Super W.T, 6:00					Q→Transmissive, Super W.T, 12:00 R→Transmissive, Super W.T, O-TFT V→Transmissive, Super W.T, VA TFT W→Transmissive, Super W.T, IPS TFT X→Transmissive, W.T, VA TFT Y→Transmissive, W.T, IPS TFT Z→Transmissive, W.T, O-TFT					
⑦	A : TFT LCD B : TFT+SCREW HOLES+CONTROL BOARD C : TFT+ SCREW HOLES +A/D BOARD D : TFT+ SCREW HOLES +A/D BOARD+CONTROL BOARD E : TFT+ SCREW HOLES +POWER BOARD					F : TFT+CONTROL BOARD G : TFT+ SCREW HOLES H : TFT+D/V BOARD I : TFT+ SCREW HOLES +D/V BOARD J : TFT+POWER BD						
⑧	Resolution:											
	A	128160	B	320234	C	320240	D	480234	E	480272	F	640480
	G	800480	H	1024600	I	320480	J	240320	K	800600	L	240400
	M	1024768	N	128128	P	1280800	Q	480800	R	640320	S	480128
	T	800320	U	8001280	V	176220	W	1280398	X	1024250	Y	1920720
	Z	800200	2	1024324	3	7201280	4	19201200	5	1366768	6	1280320
⑨	D: Digital L : LVDS M:MIPI											
⑩	Interface:											
	N	Without control board			A	8Bit		B	16Bit		H	HDMI
	I	I2C Interface			R	RS232		S	SPI Interface		U	USB
⑪	TS:											
	N	Without TS			T	Resistive touch panel			C	Capacitive touch panel (G-F-F)		
	G	Capacitive touch panel (G-G)					C1	Capacitive touch panel (G-F-F)+OCA				
	C2	Capacitive touch panel (G-F-F)+OCR					G1	Capacitive touch panel (G-G)+OCA				
	G2	Capacitive touch panel (G-G)+OCR					B	CTP+GG+USB				
⑫	Version: X:Raspberry pi											
⑬	Special Code #:Fit in with ROHS directive regulations											

--	--	--

WINSTAR DISPLAY Co., Ltd.

## **2.Summary**

TFT 2.0”is a IPS transmissive type color active matrix TFT liquid crystal display that use amorphous silicon TFT as switching devices. This module is a composed of a TFT\_LCD module, It is usually designed for industrial application and this module follows RoHs.

WINSTAR DISPLAY Co., Ltd.

### 3. General Specifications

Item	Dimension	Unit
Size	2.0"	inch
Dot Matrix	240 x RGB x 320(TFT)	dots
Module dimension	38.8(W) x 52.3(H) x3.8(D)	mm
Active area	30.60 x 40.80	mm
Pixel Pitch	0.1275 x 0.1275	mm
LCD type	TFT, Normally Black, Transmissive	
TFT Interface	MCU / SPI	
TFT Driver IC	ST7789VI or Equivalent	
Viewing angle	80/80/80/80	
Aspect Ratio	3 : 4	
Backlight Type	LED, Normally White	
CTP Driver IC	GT911 or equivalent	
CTP Interface	I2C	
CTP FW	V92	
CTP Resolution	240 * 320	
With /Without TP	With CTP	
Surface	Glare	

\*Color tone slight changed by temperature and driving voltage.



## 4. Absolute Maximum Ratings

Item	Symbol	Min	Typ	Max	Unit
Operating Temperature	TOP	-20	—	+70	°C
Storage Temperature	TST	-30	—	+80	°C

Note: Device is subject to be damaged permanently if stresses beyond those absolute maximum ratings listed above

1. Temp.  $\leq 60^{\circ}\text{C}$ , 90% RH MAX. Temp.  $> 60^{\circ}\text{C}$ , Absolute humidity shall be less than 90% RH at  $60^{\circ}\text{C}$

WINSTAR DISPLAY Co., Ltd.

# 5. Electrical Characteristics

## 5.1. Operating conditions

Item	Symbol	Condition	Min	Typ	Max	Unit
Supply Voltage For Analog	$V_{DD}$	—	2.4	3.3	3.6	V
Interface Operation Voltage	$V_{DDI}$	—	1.65	1.8	3.6	V
Supply Current For LCM	$I_{DD}$	$V_{DD} = V_{DDI} = V_{CC} = 3.0V$	—	6.0	9.0	mA
Supply CTP	$V_{CTP}$	—	2.8	—	3.3	V
	$I_{CTP}$	—	—	8.0	12.0	mA

Note: to avoid power supply noise, please avoid using driving conditions close to min, or max value

## 5.2. LED driving conditions

Parameter	Symbol	Min.	Typ.	Max.	Unit	Remark
LED current	—	—	60	—	mA	—
LED voltage	$V_{LED+}$	2.7	3.1	3.4	V	Note 1
LED Life Time	—	—	50,000	—	Hr	Note 2,3,4

Note 1 : There are 1 Groups LED

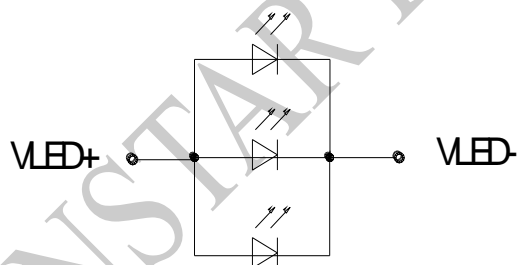

Back Light Circuit

Note 2 :  $T_a = 25\text{ }^\circ\text{C}$

Note 3 : Brightness to be decreased to 50% of the initial value

Note 4 : The single LED lamp case

## 6.DC CHARATERISTICS

Parameter	Symbol	Rating			Unit	Condition
		Min	Typ	Max		
Low level input voltage	$V_{IL}$	0	-	0.3VCC	V	
High level input voltage	$V_{IH}$	0.7VCC	-	VCC	V	

WINSTAR DISPLAY Co., Ltd.

# 7.AC Characteristics

## 7.1. 8080 Series MCU Parallel Interface Characteristics: 18/16/9/8-bit Bus

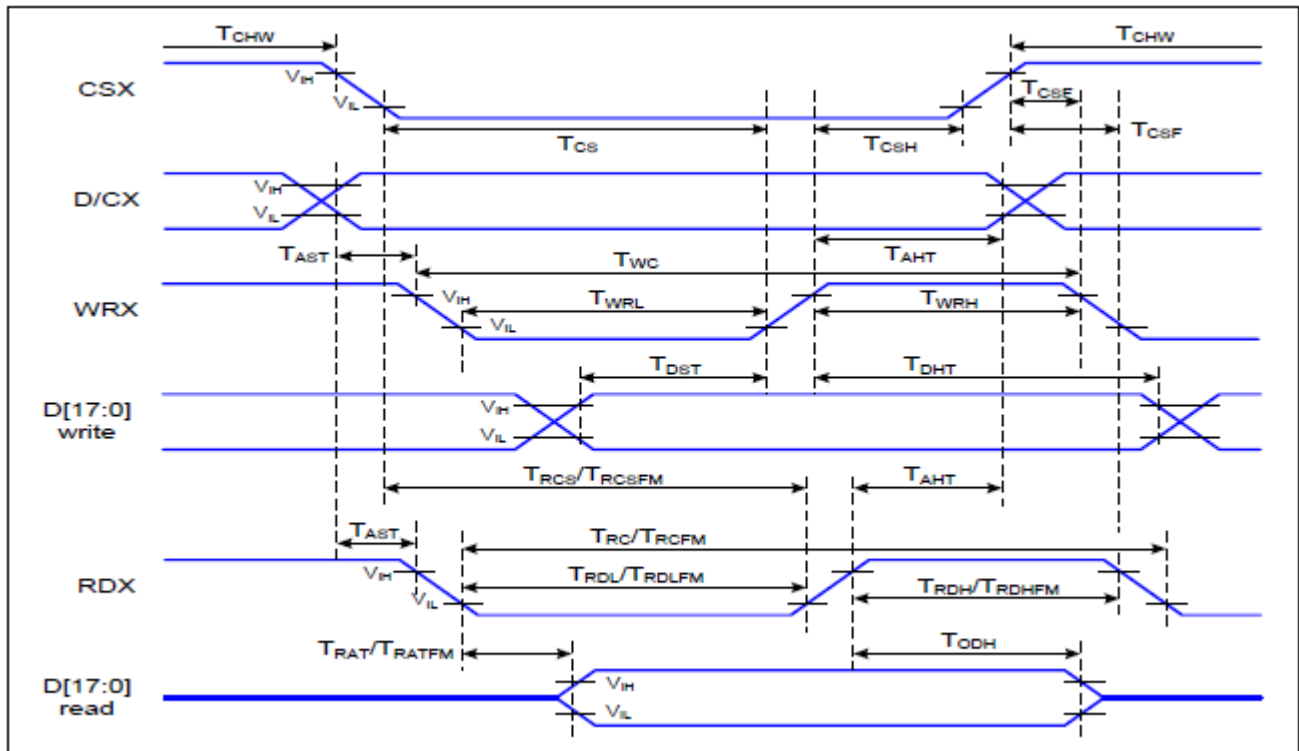

Figure 1 Parallel Interface Timing Characteristics (8080-Series MCU Interface)

WINSTAR DIS

VDDI=1.65 to 3.6V, VDD=2.4 to 3.6V, GND=0V, Ta= 25 °C

Signal	Symbol	Parameter	Min	Max	Unit	Description
D/CX	TAST	Address setup time	0		ns	-
	TAHT	Address hold time (Write/Read)	10		ns	
CSX	TCHW	Chip select "H" pulse width	0		ns	-
	TCS	Chip select setup time (Write)	15		ns	
	TRCS	Chip select setup time (Read ID)	45		ns	
	TRCSFM	Chip select setup time (Read FM)	355		ns	
	TCSF	Chip select wait time (Write/Read)	10		ns	
	TCSH	Chip select hold time	10		ns	
WRX	TWC	Write cycle	66		ns	
	TWRH	Control pulse "H" duration	15		ns	
	TWRL	Control pulse "L" duration	15		ns	
RDX (ID)	TRC	Read cycle (ID)	160		ns	When read ID data
	TRDH	Control pulse "H" duration (ID)	90		ns	
	TRDL	Control pulse "L" duration (ID)	45		ns	
RDX (FM)	TRCFM	Read cycle (FM)	450		ns	When read from frame memory
	TRDHFM	Control pulse "H" duration (FM)	90		ns	
	TRDLFM	Control pulse "L" duration (FM)	355		ns	
D[17:0]	TDST	Data setup time	10		ns	For CL=30pF
	T <sub>DHT</sub>	Data hold time	10		ns	
	T <sub>RAT</sub>	Read access time (ID)		40	ns	
	T <sub>RATFM</sub>	Read access time (FM)		340	ns	
	T <sub>ODH</sub>	Output disable time	20	80	ns	

Table 8080 Parallel Interface Characteristics

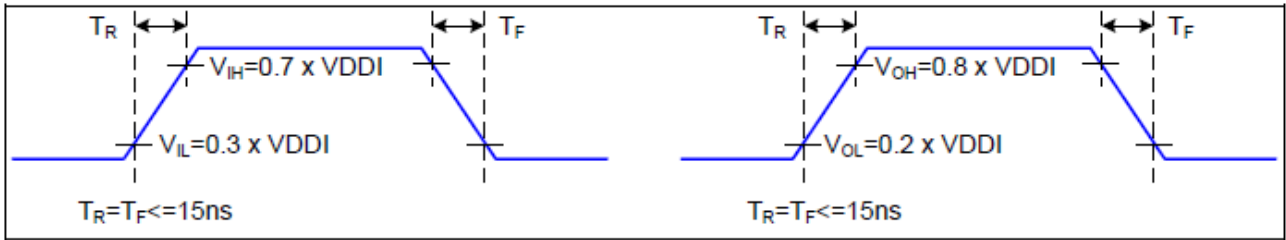

**Figure 2 Rising and Falling Timing for I/O Signal**

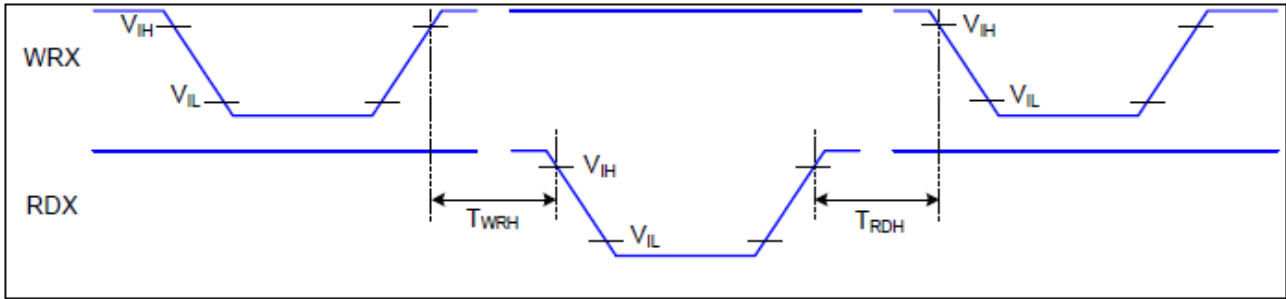

**Figure 3 Write-to-Read and Read-to-Write Timing**

Note: The rising time and falling time ( $T_r$ ,  $T_f$ ) of input signal and fall time are specified at 15 ns or less. Logic high and low levels are specified as 30% and 70% of VDDI for Input signals.

WINSTAR DISPLAY

## 7.2. 3-line Serial Interface

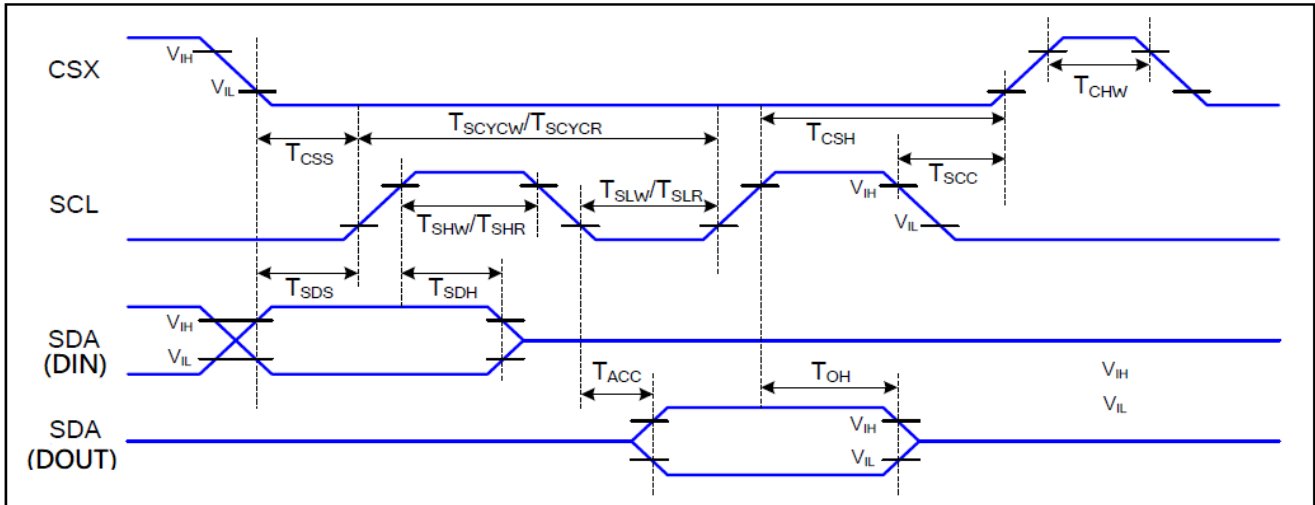

Figure 4 3-line serial Interface Timing Characteristics

VDDI=1.65 to 3.6V, VDD=2.4 to 3.6V, GND=0V, Ta= 25 °C

Signal	Symbol	Parameter	Min	Max	Unit	Description
CSX	T <sub>CSS</sub>	Chip select setup time (write)	15		ns	
	T <sub>CSH</sub>	Chip select hold time (write)	15		ns	
	T <sub>CSS</sub>	Chip select setup time (read)	60		ns	
	T <sub>SCC</sub>	Chip select hold time (read)	65		ns	
	T <sub>CHW</sub>	Chip select "H" pulse width	40		ns	
SCL	T <sub>SCYCW</sub>	Serial clock cycle (Write)	16		ns	
	T <sub>SHW</sub>	SCL "H" pulse width (Write)	7		ns	
	T <sub>SLW</sub>	SCL "L" pulse width (Write)	7		ns	
	T <sub>SCYCR</sub>	Serial clock cycle (Read)	150		ns	
	T <sub>SHR</sub>	SCL "H" pulse width (Read)	60		ns	
	T <sub>SLR</sub>	SCL "L" pulse width (Read)	60		ns	
SDA (DIN)	T <sub>SDS</sub>	Data setup time	7		ns	
	T <sub>SDH</sub>	Data hold time	7		ns	
SDA (DOUT)	T <sub>ACC</sub>	Access time	10	50	ns	For maximum CL=30pF
	T <sub>OH</sub>	Output disable time	15	50	ns	For minimum CL=8pF

Table 3-line serial Interface Characteristics

### 7.3. Reset Timing:

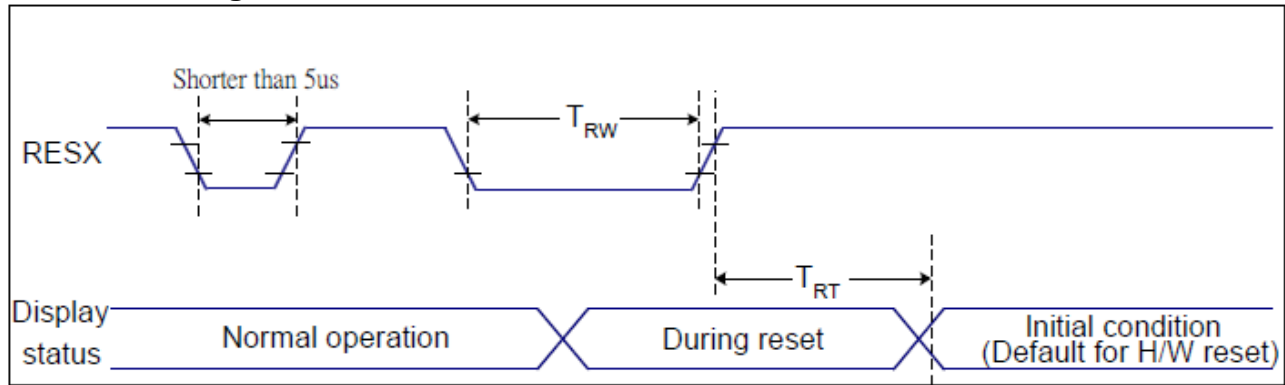

**Figure 5 Reset Timing**

VDDI=1.65 to 3.6V, VDD=2.4 to 3.6V, GND=0V, Ta=25 °C

Related Pins	Symbol	Parameter	MIN	MAX	Unit
RESX	TRW	Reset pulse duration	10	-	us
	TRT	Reset cancel	-	5 (Note 1, 5)	ms
			120 (Note 1, 6, 7)	ms	

Notes:

1. The reset cancel includes also required time for loading ID bytes, VCOM setting and other settings from NVM (or similar device) to registers. This loading is done every time when there is HW reset cancel time ( $t_{RT}$ ) within 5 ms after a rising edge of RESX.
2. Spike due to an electrostatic discharge on RESX line does not cause irregular system reset according to the table below:

RESX Pulse	Action
Shorter than 5us	Reset Rejected
Longer than 9us	Reset
Between 5us and 9us	Reset starts

3. During the Resetting period, the display will be blanked (The display is entering blanking sequence, which maximum time is 120 ms, when Reset Starts in Sleep Out –mode. The display remains the blank state in Sleep In –mode.) and then return to Default condition for Hardware Reset.
4. Spike Rejection also applies during a valid reset pulse as shown below:



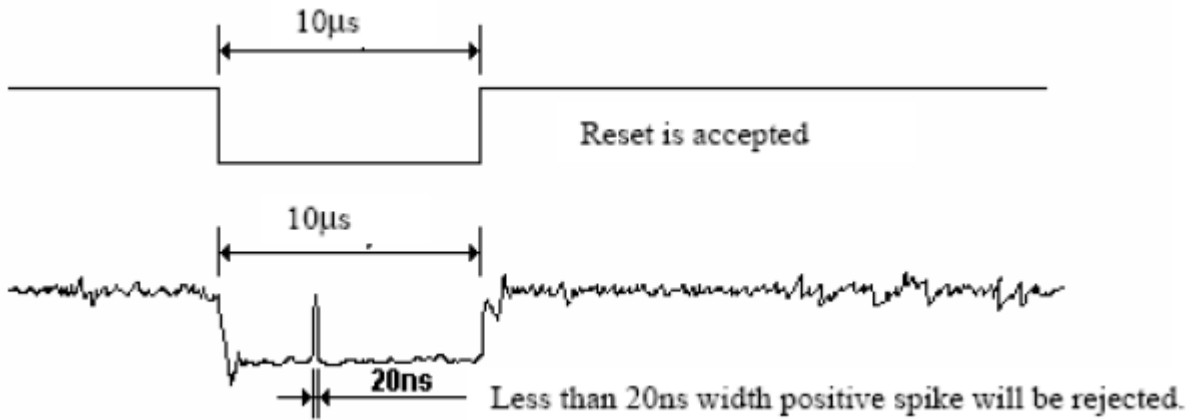

5. When Reset applied during Sleep In Mode.
6. When Reset applied during Sleep Out Mode.
7. It is necessary to wait 5msec after releasing RESX before sending commands. Also Sleep Out command cannot be sent for 120msec.

#### 7.4. Power sequences

The power on/off sequence is illustrated below

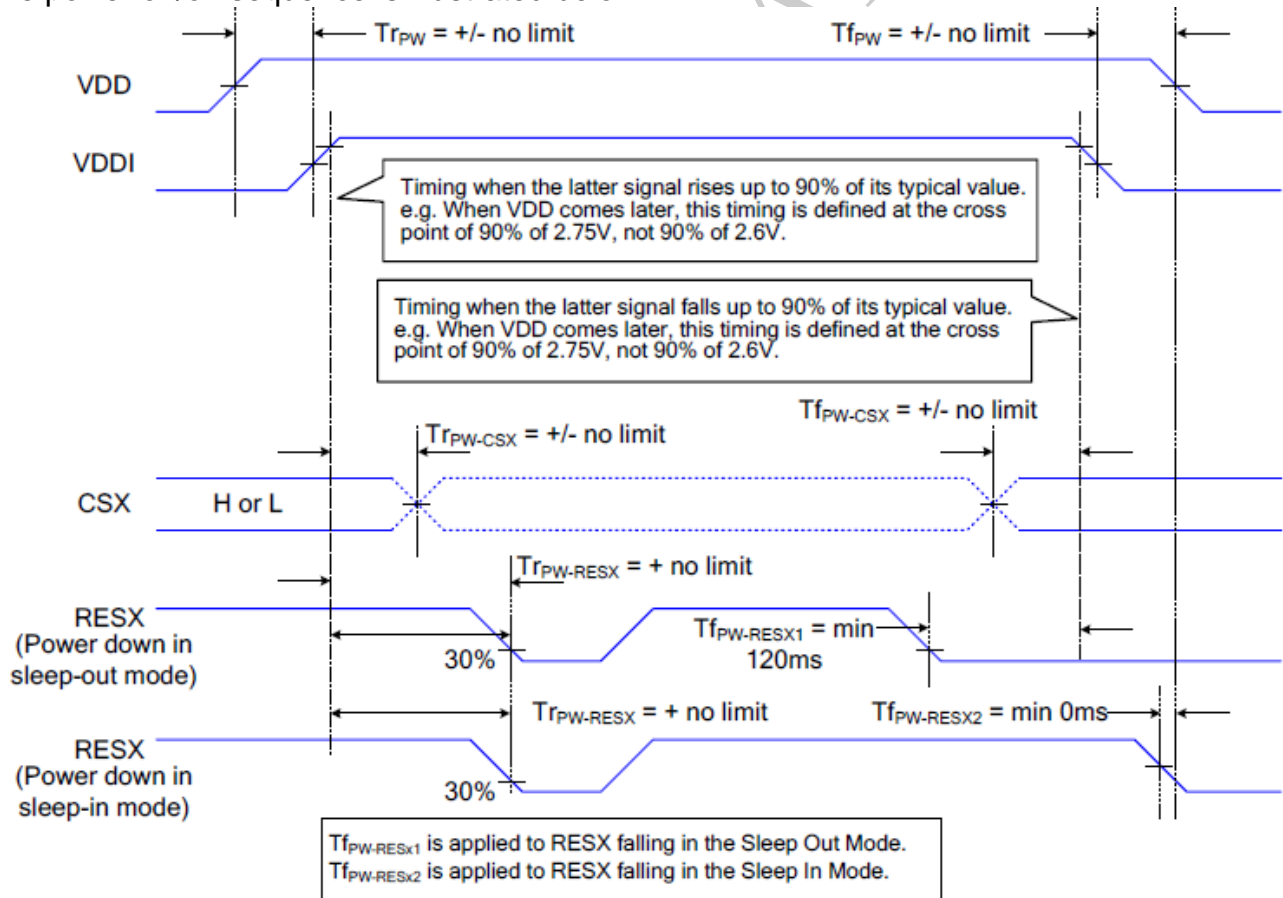

# 8. Optical Characteristics

Item	Symbol	Condition.	Min	Typ.	Max.	Unit	Remark	
Response time	Tr+ Tf	$\theta=0^\circ$ 、 $\phi=0^\circ$	-	35	45	ms	Note 3	
Contrast ratio	CR	At optimized viewing angle	640	800	-	-	Note 4	
Color Chromaticity	White	Wx	$\theta=0^\circ$ 、 $\phi=0$	0.246	0.296	0.346	Note 2,6,7	
		Wy		0.275	0.325	0.375		
Viewing angle (Gray Scale Inversion Direction)	Hor.	$\Theta_R$	$CR \geq 10$	-	80	-	Deg.	Note 1
		$\Theta_L$		-	80	-		
	Ver.	$\Phi_T$		-	80	-		
		$\Phi_B$		-	80	-		
Brightness	-	-	350	400	-	cd/m <sup>2</sup>	Center of display	
Uniformity	(U)	-	75	-	-	%	Note5	

Ta=25±2°C

Note 1: Definition of viewing angle range

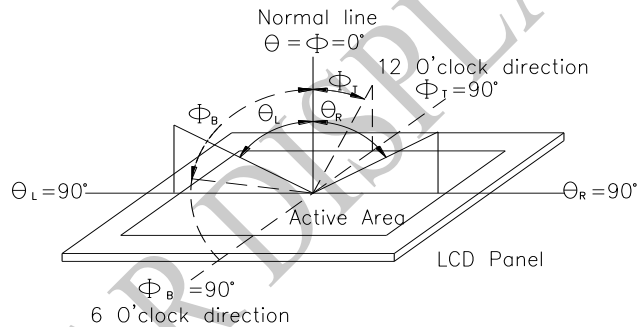

Fig. 8.1. Definition of viewing angle

Note 2: Test equipment setup:

After stabilizing and leaving the panel alone at a driven temperature for 10 minutes, the measurement should be executed. Measurement should be executed in a stable, windless, and dark room. Optical specifications are measured by Topcon BM-7 or BM-5 luminance meter 1.0° field of view at a distance of 50cm and normal direction.

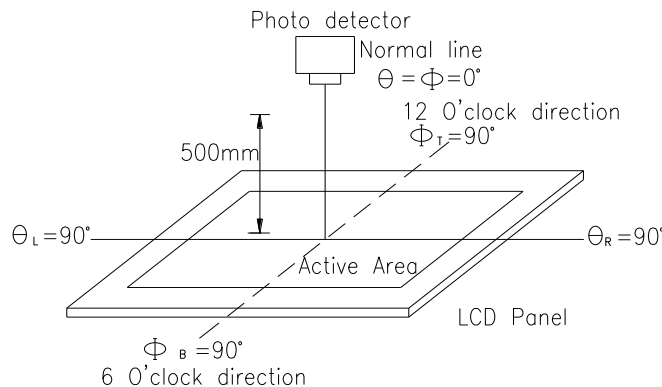
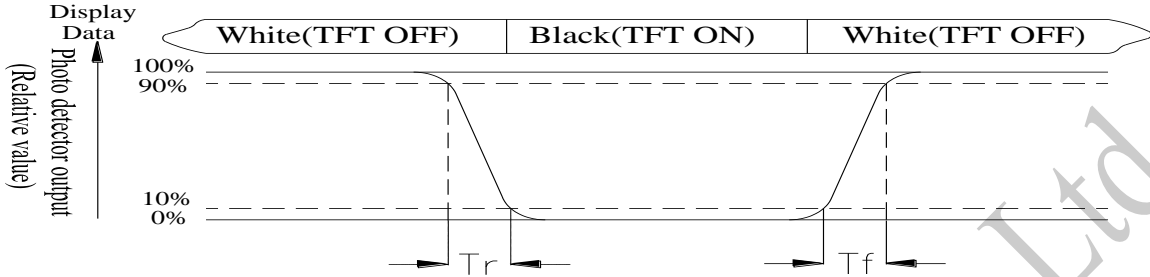

Fig. 8.2. Optical measurement system setup

**Note 3: Definition of Response time:**

The response time is defined as the LCD optical switching time interval between "White" state and "Black" state. Rise time,  $T_r$ , is the time between photo detector output intensity changed from 90% to 10%. And fall time,  $T_f$ , is the time between photo detector output intensity changed from 10% to 90%



**Note 4: Definition of contrast ratio:**

The contrast ratio is defined as the following expression.

$$\text{Contrast ratio (CR)} = \frac{\text{Luminance measured when LCD on the "White" state}}{\text{Luminance measured when LCD on the "Black" state}}$$

**Note 5: Definition of Luminance Uniformity**

Active area is divided into 9 measuring areas (reference the picture in below). Every measuring point is placed at the center of each measuring area.

$$\text{Luminance Uniformity (U)} = \text{Lmin/Lmax} \times 100\%$$

L = Active area length

W = Active area width

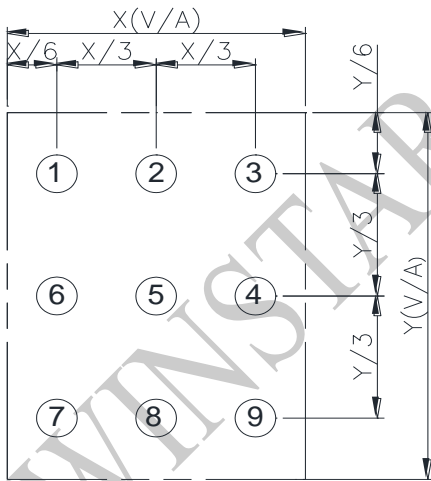

Fig 8.3. Definition of uniformity

**Note 6: Definition of color chromaticity (CIE 1931)**

Color coordinates measured at the center point of LCD

**Note 7:** Measured at the center area of the panel when all the input terminals of LCD panel are electrically opened.

# 9.Interface

## 9.1. LCM PIN Definition

NO	Symbol	Function																																				
1	GND	Ground																																				
2	NC(YU)	No connection																																				
3	NC(XL)	No connection																																				
4	NC(YD)	No connection																																				
5	NC(XR)	No connection																																				
6	NC	No connection																																				
7	VDD	Power supply																																				
8	VDDI	Power Supply for I/O System.																																				
9	TE	Tearing effect signal is used to synchronize MCU to frame memory writing. If not used, please let this pin open																																				
10	CSX	Chip selection pin Low enable. High disable.																																				
11	DCX(SCL)	(D/CX): This pin is used to select "Data or Command" in the parallel interface. DCX='1': display data or parameter. DCX='0': command data. (SCL): When SPI mode, This pin is used to be serial interface clock.																																				
12	WRX(D/CX)	Display data/command selection Second Data lane in 2 data lane serial interface. (WRX): Write enable in MCU parallel interface. (D/CX): When 4-SPI mode, This pin in 4-line serial interface If not used, please fix this pin at VDDI or GND.																																				
13	RDX	-Read enable in 8080 MCU parallel interface. -If not used, please fix this pin at VDDI or GND.																																				
14~29	DB0~DB15	Data bus line																																				
30	RESX	System reset pin. signal is active low																																				
31	IM0	The MCU interface mode select.																																				
32	IM1																																					
33	IM2		<table border="1"> <thead> <tr> <th>IM2</th> <th>IM1</th> <th>IM0</th> <th>MPU Interface Mode</th> <th>Data pin</th> </tr> </thead> <tbody> <tr> <td>0</td> <td>0</td> <td>0</td> <td>80-8bit parallel I/F</td> <td>DB[7:0]</td> </tr> <tr> <td>0</td> <td>0</td> <td>1</td> <td>80-16bit parallel I/F</td> <td>DB[15:0]</td> </tr> <tr> <td>0</td> <td>1</td> <td>0</td> <td>80-9bit parallel I/F</td> <td>DB[8:0]</td> </tr> <tr> <td>0</td> <td>1</td> <td>1</td> <td>80-18bit parallel I/F</td> <td>DB[17:0],</td> </tr> <tr> <td>1</td> <td>0</td> <td>1</td> <td>3-line 9bit serial I/F</td> <td>SDA: in/out</td> </tr> <tr> <td>1</td> <td>1</td> <td>0</td> <td>4-line 8bit serial I/F</td> <td>SDA: in/out</td> </tr> </tbody> </table>	IM2	IM1	IM0	MPU Interface Mode	Data pin	0	0	0	80-8bit parallel I/F	DB[7:0]	0	0	1	80-16bit parallel I/F	DB[15:0]	0	1	0	80-9bit parallel I/F	DB[8:0]	0	1	1	80-18bit parallel I/F	DB[17:0],	1	0	1	3-line 9bit serial I/F	SDA: in/out	1	1	0	4-line 8bit serial I/F	SDA: in/out
			IM2	IM1	IM0	MPU Interface Mode	Data pin																															
			0	0	0	80-8bit parallel I/F	DB[7:0]																															
			0	0	1	80-16bit parallel I/F	DB[15:0]																															
			0	1	0	80-9bit parallel I/F	DB[8:0]																															
0	1	1	80-18bit parallel I/F	DB[17:0],																																		
1	0	1	3-line 9bit serial I/F	SDA: in/out																																		
1	1	0	4-line 8bit serial I/F	SDA: in/out																																		

34~35	DB16~DB17	Data bus line
36	VLED-	Cathode of LED backlight.
37	VLED-	Cathode of LED backlight.
38	VLED+	Anode of LED backlight.
39	NC(SDA)	When SPI mode, This pin is SPI interface input/output pin. The data is latched on the rising edge of the SCL signal. If not used(NC), please fix this pin at VDDI or GND level.
40	NC	No connection

## 9.2. CTP PIN Definition

Pin	Symbol	Function	Remark
1	VSS	Ground for analog circuit	
2	VDDT	Power Supply :	
3	SCL	I2C clock inputI2C clock input	
4	NC	No connect	
5	SDA	I2C data input and output	
6	NC	No connect	
7	/RST	External Reset, Low is active	
8	NC	No connect	
9	/INT	External interrupt to the host	
10	VSS	Ground for analog circuit	

# 10. Block Diagram

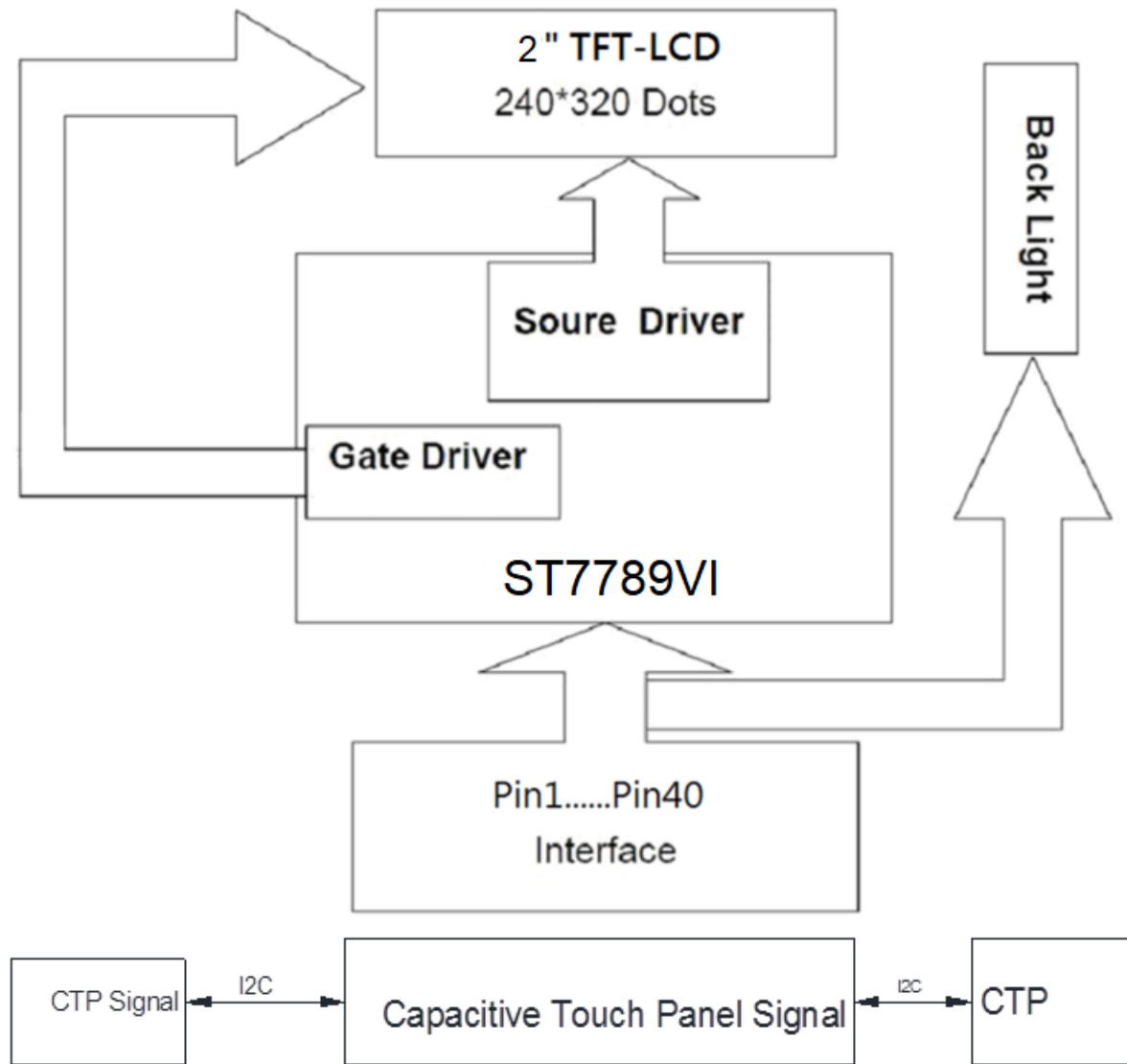

# 11. Reliability

Content of Reliability Test (Wide temperature, -20°C~70°C)

Environmental Test			
Test Item	Content of Test	Test Condition	Note
High Temperature storage	Endurance test applying the high storage temperature for a long time.	80°C 200hrs	2
Low Temperature storage	Endurance test applying the low storage temperature for a long time.	-30°C 200hrs	1,2
High Temperature Operation	Endurance test applying the electric stress (Voltage & Current) and the thermal stress to the element for a long time.	70°C 200hrs	—
Low Temperature Operation	Endurance test applying the electric stress under low temperature for a long time.	-20°C 200hrs	1
High Temperature/ Humidity Operation	The module should be allowed to stand at 60°C,90%RH max	60°C,90%RH 96hrs	1,2
Thermal shock resistance	The sample should be allowed stand the following 10 cycles of operation <div style="text-align: center;"> <p style="margin: 0;">-20°C    25°C    70°C</p> <p style="margin: 0;">30min    5min    30min</p> <p style="margin: 0;">1 cycle</p> </div>	-20°C/70°C 10 cycles	—
Vibration test	Endurance test applying the vibration during transportation and using.	Total fixed amplitude : 1.5mm Vibration Frequency : 10~55Hz One cycle 60 seconds to 3 directions of X,Y,Z for Each 15 minutes	3
Static electricity test	Endurance test applying the electric stress to the finished product housing.	Contact±4KV Air±8KV 10 times	4

Note1: No dew condensation to be observed.

Note2: The function test shall be conducted after 4 hours storage at the normal Temperature and humidity after remove from the test chamber.

Note3: The packing have to including into the vibration testing.

Note4: Temporary degradation or loss in operation or function, which is able to be recovered by self-recovery function

# 12.Touch Panel Information

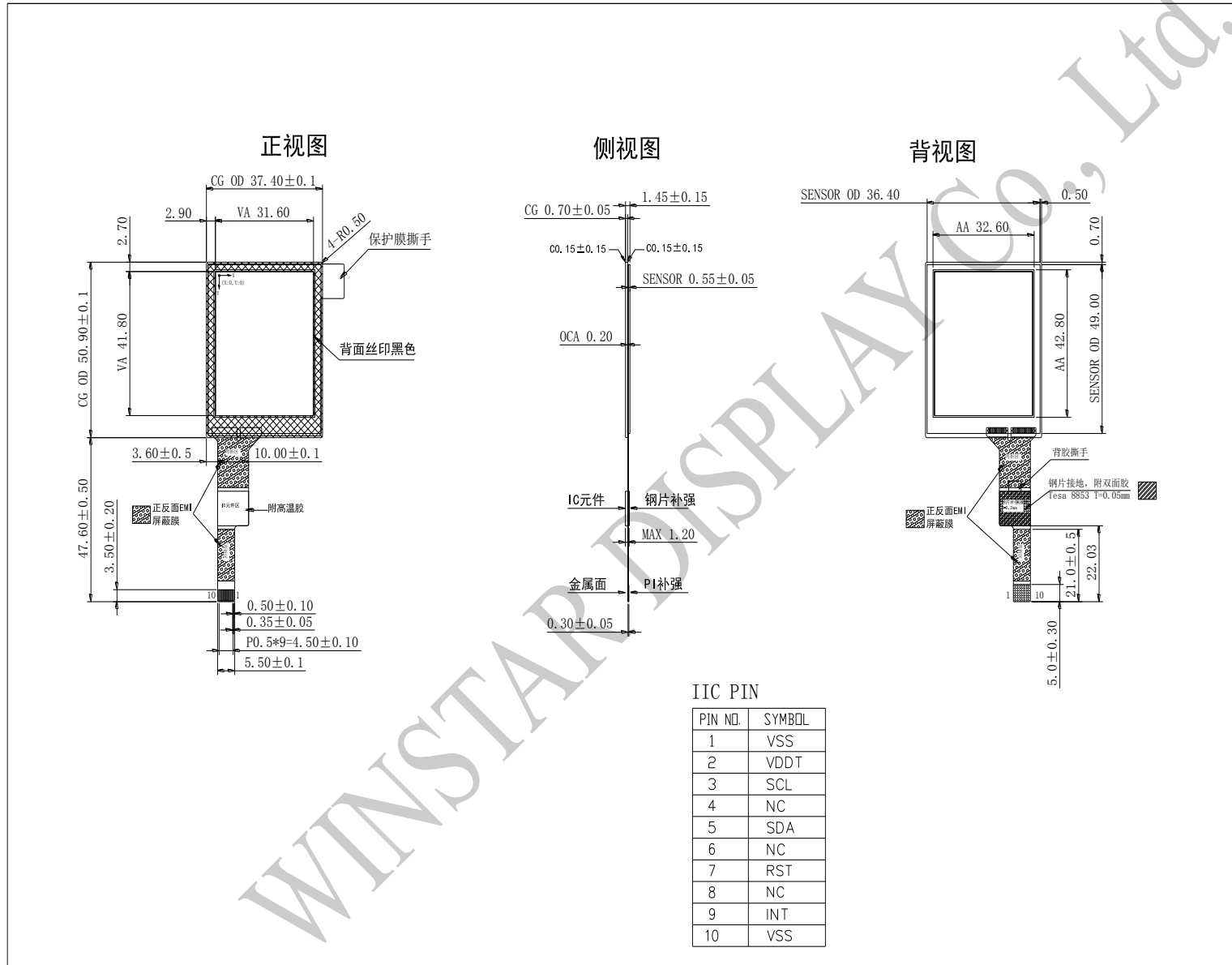



# 13. Contour Drawing

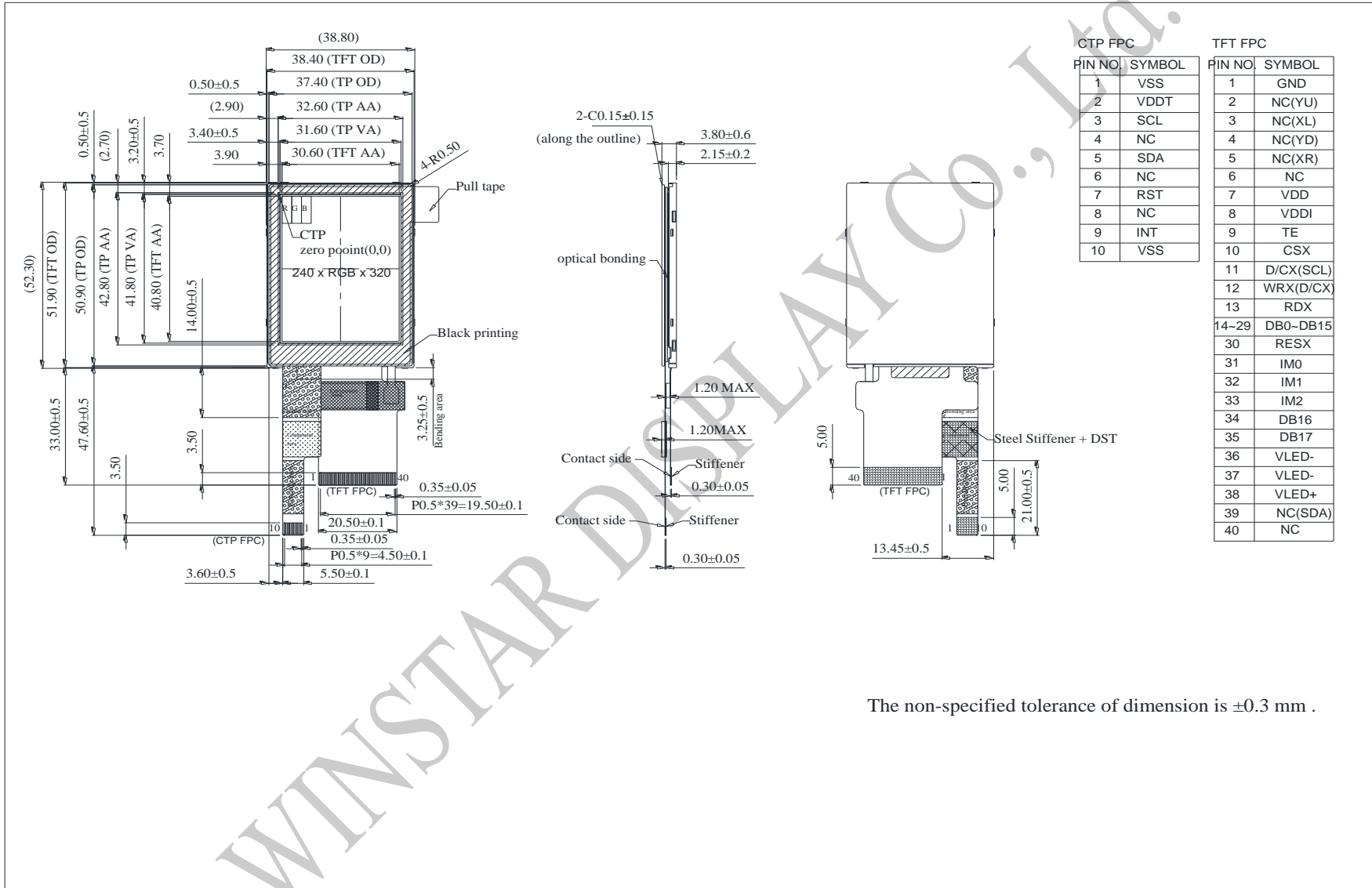

# 14.Initial Code For Reference

void ST7789SV\_WF0200B(void) for SPI & MCU mode

```
{
    Write_Command(0x11); //Sleep out
    delay(150);          //Delay 120ms

    Write_Command(0x36); //
    Write_Data(0x00);

    Write_Command(0x3A); //
    Write_Data(0x55);

    //ST7789S Frame rate setting
    Write_Command(0xb2); //Porch Setting
    Write_Data(0x0c);
    Write_Data(0x0c);
    Write_Data(0x00);
    Write_Data(0x33);
    Write_Data(0x33);
    Write_Command(0xb7); //Gate Control
    //Write_Data(0x35); //vgh vgl
    Write_Data(0x64);

    //ST7789S Power setting
    Write_Command(0xbb); //Gate Control VCOMS=1.425V
    Write_Data(0x30);
    Write_Command(0xc0); //LCM Control
    Write_Data(0x2c);
    Write_Command(0xc2); //VDV and VRH Command Enable
    Write_Data(0x01);
    Write_Command(0xc3); //VRH Set (AVDD=VRH+1.675
    Write_Data(0x0b);
    Write_Command(0xc4); //VRH Set
    Write_Data(0x20);
    Write_Command(0xc6); //Frame Rate Control in Normal Mode
    Write_Data(0x0f);
    Write_Command(0xca); //Register Value Selection 2
    Write_Data(0x0f);
    Write_Command(0xc8); //Register Value Selection 1
    Write_Data(0x08);
    Write_Command(0x55); //Write Content Adaptive Brightness Control and Color Enhancement
    Write_Data(0x90);
    Write_Command(0xd0); //Power Control
    Write_Data(0xa4);
    Write_Data(0xa1);
    Write_Command(0x35); //

    Write_Command(0x26); //Set Gamma
    Write_Data(0x02);

    //ST7789S gamma setting
```

```
Write_Command(0xe0);
Write_Data(0xd0);
Write_Data(0x00);
Write_Data(0x02);
Write_Data(0x07);
Write_Data(0x0b);
Write_Data(0x1a);
Write_Data(0x31);
Write_Data(0x54);
Write_Data(0x40);
Write_Data(0x29);
Write_Data(0x12);
Write_Data(0x12);
Write_Data(0x12);
Write_Data(0x17);
Write_Command(0xe1);
Write_Data(0xd0);
Write_Data(0x00);
Write_Data(0x02);
Write_Data(0x07);
Write_Data(0x05);
Write_Data(0x25);
Write_Data(0x2d);
Write_Data(0x44);
Write_Data(0x45);
Write_Data(0x1c);
Write_Data(0x18);
Write_Data(0x16);
Write_Data(0x1c);
Write_Data(0x1d);
```

```
Write_Command(0x21);
```

```
Write_Command(0x2A);
Write_Data(0x00);
Write_Data(0x00);
Write_Data(0x00);
Write_Data(0xEF);
```

```
Write_Command(0x2B);
Write_Data(0x00);
Write_Data(0x0);
Write_Data(0x01);
Write_Data(0x3F);
```

```
Write_Command(0x29);
```

```
}
```



**1、Panel Specification :**

- 1. Panel Type :  Pass  NG , \_\_\_\_\_
- 2. View Direction :  Pass  NG , \_\_\_\_\_
- 3. Numbers of Dots :  Pass  NG , \_\_\_\_\_
- 4. View Area :  Pass  NG , \_\_\_\_\_
- 5. Active Area :  Pass  NG , \_\_\_\_\_
- 6. Operating :  Pass  NG , \_\_\_\_\_
- 7. Storage Temperature :  Pass  NG , \_\_\_\_\_
- 8. Others : \_\_\_\_\_

**2、Mechanical**

- 1. PCB Size :  Pass  NG , \_\_\_\_\_
- 2. Frame Size :  Pass  NG , \_\_\_\_\_
- 3. Material of Frame :  Pass  NG , \_\_\_\_\_
- 4. Connector Position :  Pass  NG , \_\_\_\_\_
- 5. Fix Hole Position :  Pass  NG , \_\_\_\_\_
- 6. Backlight Position :  Pass  NG , \_\_\_\_\_
- 7. Thickness of PCB :  Pass  NG , \_\_\_\_\_
- 8. Height of Frame to PCB :  Pass  NG , \_\_\_\_\_
- 9. Height of Module :  Pass  NG , \_\_\_\_\_
- 10. Others :  Pass  NG , \_\_\_\_\_

**3、Relative Hole Size :**

- 1. Pitch of Connector :  Pass  NG , \_\_\_\_\_
- 2. Hole size of Connector :  Pass  NG , \_\_\_\_\_
- 3. Mounting Hole size :  Pass  NG , \_\_\_\_\_
- 4. Mounting Hole Type :  Pass  NG , \_\_\_\_\_
- 5. Others :  Pass  NG , \_\_\_\_\_

**4、Backlight Specification :**

- 1. B/L Type :  Pass  NG , \_\_\_\_\_
- 2. B/L Color :  Pass  NG , \_\_\_\_\_
- 3. B/L Driving Voltage (Reference for LED) :  Pass  NG , \_\_\_\_\_
- 4. B/L Driving Current :  Pass  NG , \_\_\_\_\_
- 5. Brightness of B/L :  Pass  NG , \_\_\_\_\_
- 6. B/L Solder Method :  Pass  NG , \_\_\_\_\_
- 7. Others :  Pass  NG , \_\_\_\_\_



Winstar Module Number : \_\_\_\_\_

Page: 2

**5、Electronic Characteristics of Module :**

- 1. Input Voltage :  Pass  NG , \_\_\_\_\_
- 2. Supply Current :  Pass  NG , \_\_\_\_\_
- 3. Driving Voltage for LCD :  Pass  NG , \_\_\_\_\_
- 4. Contrast for LCD :  Pass  NG , \_\_\_\_\_
- 5. B/L Driving Method :  Pass  NG , \_\_\_\_\_
- 6. Negative Voltage Output :  Pass  NG , \_\_\_\_\_
- 7. Interface Function :  Pass  NG , \_\_\_\_\_
- 8. LCD Uniformity :  Pass  NG , \_\_\_\_\_
- 9. ESD test :  Pass  NG , \_\_\_\_\_
- 10. Others :  Pass  NG , \_\_\_\_\_

**6、Summary :**

Sales signature : \_\_\_\_\_

Customer Signature : \_\_\_\_\_

Date :     /     /     \_\_\_\_\_

